

xStart

DILM contactor
ZB/Z5 overload relays
ZEB and C441 overload relays

PKZ Motor-protective circuit breaker
NZM Motor-protective circuit breaker

Efficient solutions for motor control



EATON

Powering Business Worldwide

Starter selection table



Overview for DILM contactor / Overload relays / PKZ & NZM motor breaker

Contactor (3 Pole)



Type DIL		M9	M12	M15	M17	M25	M32	M40	M50	M65
AC3 KW rating		4	5.5	7.5	7.5	11	15	18.5	22	30
AC1 rating at 40 (Open) AC1 ampere		22	22	38	40	45	45	60	70	85
AC3 rating AC3 ampere	220 - 240 VAC	9	12	15.5	18	25	32	40	50	65
50 - 60 HZ	380 - 440 VAC	9	12	15.5	18	25	32	40	50	65
	500 VAC	7	10	12.5	18	25	32	40	50	65
	690 VAC	5	7	9	12	15	18	25	32	37
Contactor coil voltage		AC Coil : 24V50/60HZ ; 11050/60HZ ; 220V50/60HZ ; 230V50HZ ; 240V60HZ, other voltages please enquiry DC coil :24V, other voltages please enquiry								
Contactor dimensions (W x H x D)mm		45 x 77 x 74			45 x 91 x 79			55 x 115 x 114		



Overload relays

Type Z	ZB12-..	ZB32-..	ZB65-..
			
Overload relays ampere setting	0.1-0.16 0.16-0.24 0.24-0.4 0.4-0.6 0.6-1 1.6-2.4	2.4-4 4-6 6-10 10-16	16-24 24-32
			6-10 10-16 16-24 24-40 40-57 50-65

Auxiliary contact for DILM

Type	..DILM	DILM150-XHI.. or DILM1000-XHI	DILM1000-XHI
			

Motor breaker (3 Pole)

Type PKZM0../PKZM4../NZM..	PKZM0-..	PKZM4-..	LZMB1-M..
			
Motor breaker ampere setting	0.1-0.16 0.16-0.25 0.25-0.4 0.4-0.63 0.63-1 1-2.5 2.5-4	4-6.3 6.3-10 8-12 10-16 16-20 20-25 25-32	24-32 32-40 40-50 50-58 55-63
			16-20 20-25 25-32 32-40 40-50 50-63 63-80 80-100
Motor breaker dimensions (W x H x D)mm	45 x 93 x 70		90 x 165 x 73

Starter selection table



M80	M95	M115	M150	M185	M225	M250	M300	M400	M500	M580	M650	M750	M820	M1000
37	45	55	75	90	110	132	160	200	250	315	355	400	450	560
130	130	190	190	337	386	429	490	612	857	980	1041	1102	1125	1225
80	95	115	150	185	225	250	300	400	500	580	650	750	820	1000
80	95	115	150	185	225	250	300	400	500	580	650	750	820	1000
80	95	115	150	185	225	250	300	400	500	580	650	750	820	1000
80	95	115	150	185	225	250	300	360	360	580	650	750	820	1000

Standard coil : RA250 (110-250Vac 40-60HZ / 110-250Vdc), other voltages please enquiry

90 x 170 x 160

140 x 180 x 208

160 x 200 x 216

250 x 232 x 232

ZB150-..

Z5-../FF250

ZEB+ZEB-XCT... or C441



25-35
35-50
50-70
70-100
95-125
120-150

50-70
70-100
95-125
120-160
120-220
220-250

40-820

LZMB2-M..

LZMN3-ME..

LZMN4-ME..



100-125
125-160
160-200

110-220
175-350
225-450

275-550
438-875
700-1400

105 x 206 x 108

140 x 297 x 126

210 x 401 x 146

Technical data

Rated currents of three-phase motors (guidelines for squirrel-cage motors)

Minimum fuse size for the protection of three-phase motors

The maximum size is governed by the requirement of the associated switchgear or overload

Motor rating			230 V			400 V			500 V			690 V		
			Rating Motor current	Fuse Starting direct	Y / Δ	Rating Motor current	Fuse Starting direct	Y / Δ	Rating Motor current	Fuse Starting direct	Y / Δ	Rating Motor current	Fuse Starting direct	Y / Δ
kW	cos	n (%)	A	A	A	A	A	A	A	A	A	A	A	A
0.06	0.7	58	0.37	2	-	0.21	2	-	0.17	2	-	0.12	2	-
0.09	0.7	60	0.54	2	-	0.31	2	-	0.25	2	-	0.18	2	-
0.12	0.7	60	0.72	4	2	0.41	2	-	0.33	2	-	0.24	2	-
0.18	0.7	62	1.04	4	2	0.6	2	-	0.48	2	-	0.35	2	-
0.25	0.7	62	1.4	4	2	0.8	4	2	0.7	2	-	0.5	2	-
0.37	0.72	66	2	6	4	1.1	4	2	0.9	2	2	0.7	2	-
0.55	0.75	69	2.7	10	4	1.5	4	2	1.2	4	2	0.9	4	2
0.75	0.79	74	3.2	10	4	1.9	6	4	1.5	4	2	1.1	4	2
1.1	0.81	74	4.6	10	6	2.6	6	4	2.1	6	4	1.5	4	2
1.5	0.81	74	6.3	16	10	3.6	6	4	2.9	6	4	2.1	6	4
2.2	0.81	78	8.7	20	10	5	10	6	4	10	4	2.9	10	4
3	0.82	80	11.5	25	16	6.6	16	10	5.3	16	6	3.8	10	4
4	0.82	83	14.8	32	16	8.5	20	10	6.8	16	10	4.9	16	6
5.5	0.82	86	19.6	32	25	11.3	25	16	9	20	16	6.5	16	10
7.5	0.82	87	26.4	50	32	15.2	32	16	12.1	25	16	8.8	20	10
11	0.84	87	38	80	40	21.7	40	25	17.4	32	20	12.6	25	16
15	0.84	88	51	100	63	29.3	63	32	23.4	50	25	17	32	20
18.5	0.84	88	63	125	80	36	63	40	28.9	50	32	20.9	32	25
22	0.84	92	71	125	80	41	80	50	33	63	32	23.8	50	25
30	0.85	92	96	200	100	55	100	63	44	80	50	32	63	32
37	0.86	92	117	200	125	68	125	80	54	100	63	39	80	50
45	0.86	93	141	250	160	81	160	100	65	125	80	47	80	63
55	0.86	93	173	250	200	99	200	125	79	160	80	58	100	63
75	0.86	94	233	315	250	134	200	160	107	200	125	78	160	100
90	0.86	94	279	400	315	161	250	200	129	200	160	93	160	100
110	0.86	94	342	500	400	196	315	200	157	250	160	114	200	125
132	0.87	95	401	630	500	231	400	250	184	250	200	134	250	160
160	0.87	95	486	630	630	279	400	315	224	315	250	162	250	200
200	0.87	95	607	800	630	349	500	400	279	400	315	202	315	250
250	0.87	95	-	-	-	437	630	500	349	500	400	253	400	315
315	0.87	96	-	-	-	544	800	630	436	630	500	316	500	400
400	0.88	96	-	-	-	683	1000	800	547	800	630	396	630	400
450	0.88	96	-	-	-	769	1000	800	615	800	630	446	630	630
500	0.88	97	-	-	-	-	-	-	-	-	-	491	630	630
560	0.88	97	-	-	-	-	-	-	-	-	-	550	800	630
630	0.88	97	-	-	-	-	-	-	-	-	-	618	800	630

Notes

The rated motor currents apply to normal, internally-ventilated and enclosed fan-cooled three-phase motors at 1500rpm.

D.O.L. starting: Maximum starting current 6 x rated motor current. Maximum starting time 5 seconds.

Y/Δ starting: Maximum starting current 2 x rated motor current. Maximum starting time 15 seconds. Set the overload relay in the phase lead to 0.58 x rated motor current.

Rated fuse currents for Y/Δ starting also apply to three-phase motors with slip-ring rotors.

Use a larger fuse if the rated current or starting current is higher and/so if the starting time is longer.

The table applies to "slow" or "gI" fuses (VDE 0636)

LV h.b.c. fuses with aM characteristics, select fuse size to match rated current

Technical specifications

General

Standard	IEC/EN 60947, VDE0660, UL, CSA
Lifespan, mechanical AC operated	10 x 10 ⁶
Lifespan, mechanical DC operated	10 x 10 ⁶
Ambient Temperature (open) (°C)	-25 / 60
Rated impulse withstand voltage U _{imp} (VAC)	8000
Rated insulation voltage U _i (VAC)	690
Rated Operation Voltage U _e (VAC)	690

Operating characteristics

Starting	From rest
Stopping	After attaining full running speed

Electrical characteristics

Make	Up to 6 x rated motor current
Break	Up to 1 x rated motor current
Utilization category	100% AC-3

Typical applications

- Pumps
- Escalators
- Mixers
- Fans
- Conveyor belts
- Agitators
- Valves
- Bucket elevators
- Air conditioning systems

Normal switching duty

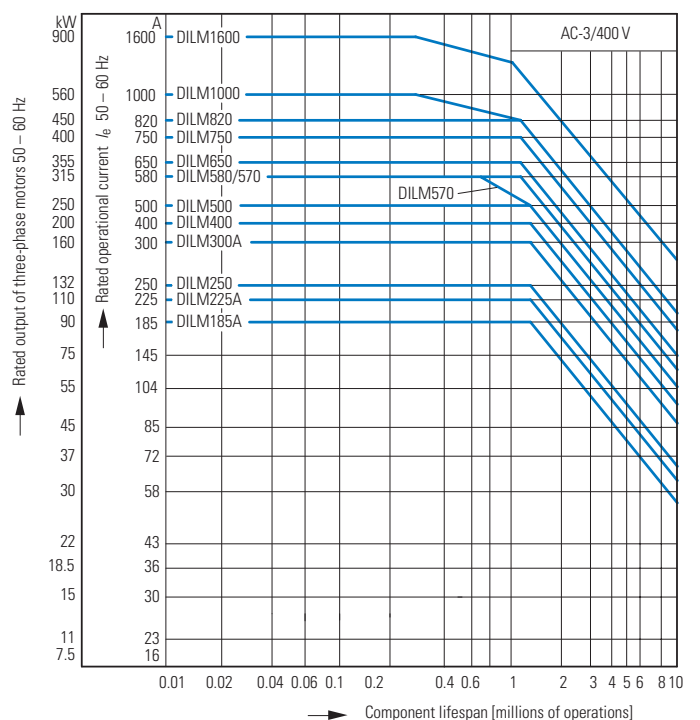
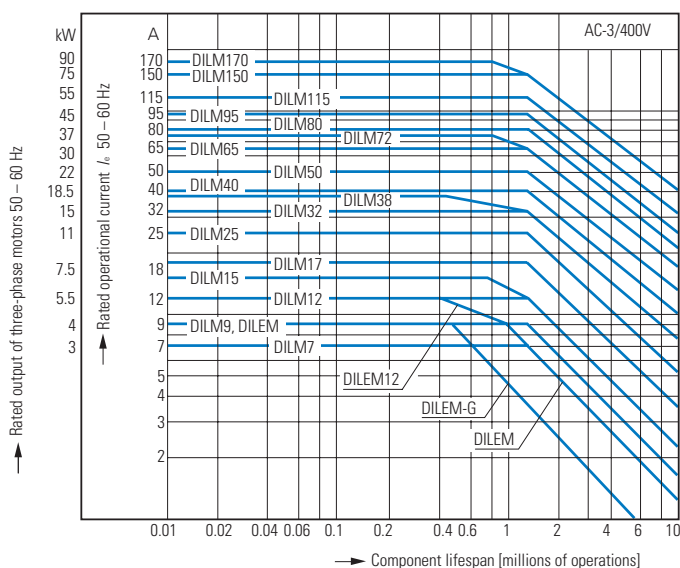

Overload relays

Technical specifications	ZE	ZB12, ZB32	ZB65	ZB150(KK)	ZEB	C441
General						
Standard	IEC/EN 60947, VDE0660, UL, CSA					
Climatic proofing	Damp heat, constant, to IEC 60068-2-78; Damp heat, cyclic, to IEC 60068-2-30					
Ambient temperature (open) (°C)	-25 / 50	-25 / 50	-25 / 50	-25 / 50	-25 / 65	-25 / 50
Rated impulse withstand voltage (VAC)	6000	6000	6000	8000	6000	6000
Rated insulation voltage (VAC)	690	690	690	1000	690	600(three-phase voltage)
Rated Operation Voltage (VAC)	690	690	690	1000	690	240/480/600
Suitable for protection of EEx e-motors	Yes	Yes	Yes	Yes	Yes	Yes
Phase-failure sensitivity	Yes	Yes	Yes	Yes	Yes	Yes

Tripping characteristics

These tripping characteristics are mean values of the spread at 20 C ambient temperature in a cold state. Tripping time depends on the response current. With devices at operating temperature, the tripping time of the overload relay reduce to approximately 25% of the read value.

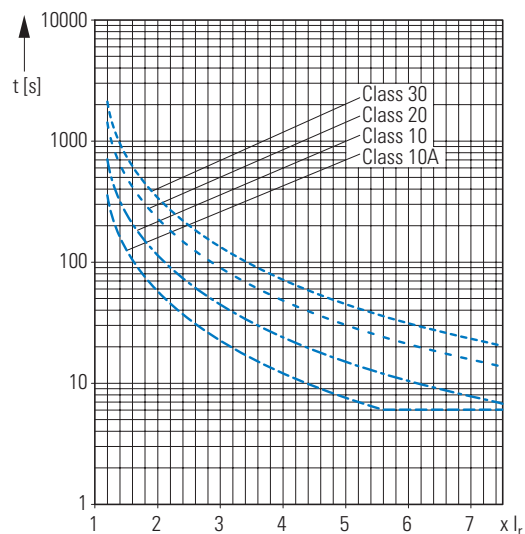
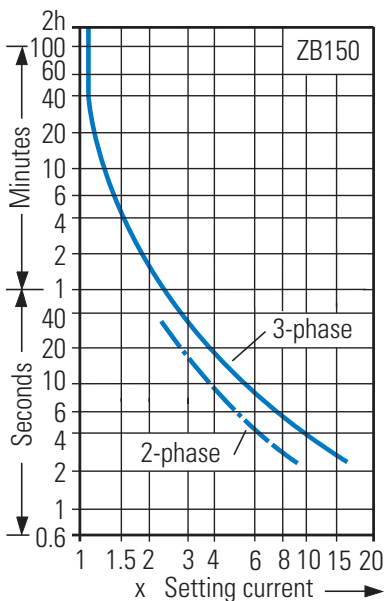
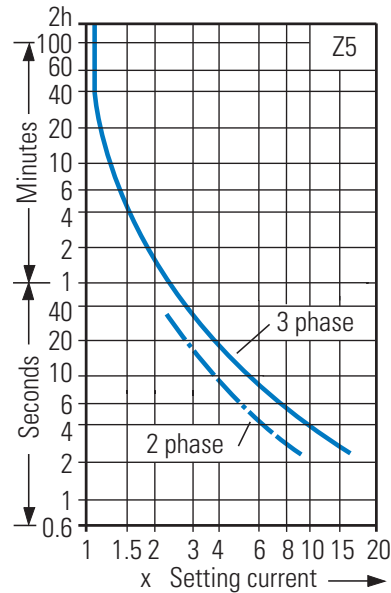
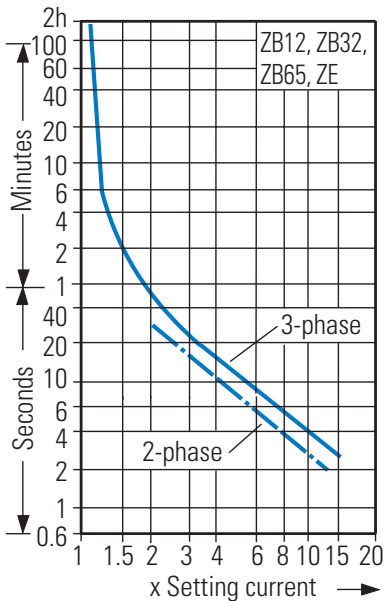

LZM MCCB for motor operation

Technical specifications	LZMB1	LZMB2	LZMN3	LZMN4
General				
Standard	IEC/EN 60947	IEC/EN 60947	IEC/EN 60947	IEC/EN 60947
Ambient temperature (open) (°C)	-25 / 70	-25 / 70	-25 / 70	-25 / 70
Rated Operational Voltage (VAC)	690	690	690	690
Rated short-circuit breaking capacity $I_{cu}=I_{cs}$ (KA)	25	25	50	50
Electrical Life Span AC-3 at 400/415VAC (Operations)	7500	6500	2000	2000
Mechanical Life Span (Operations)	20000	20000	15000	10000
Total opening delay on short-circuit (ms)	<10	<10	<10	<25

Motor protection with LZM1

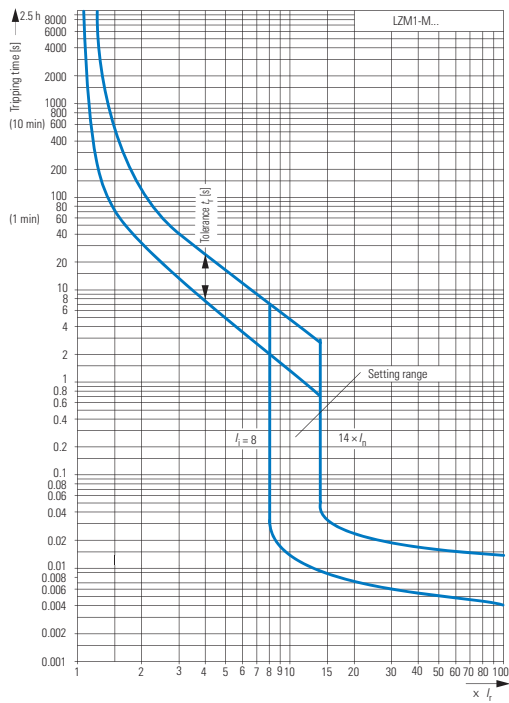

Motor protection with LZM2

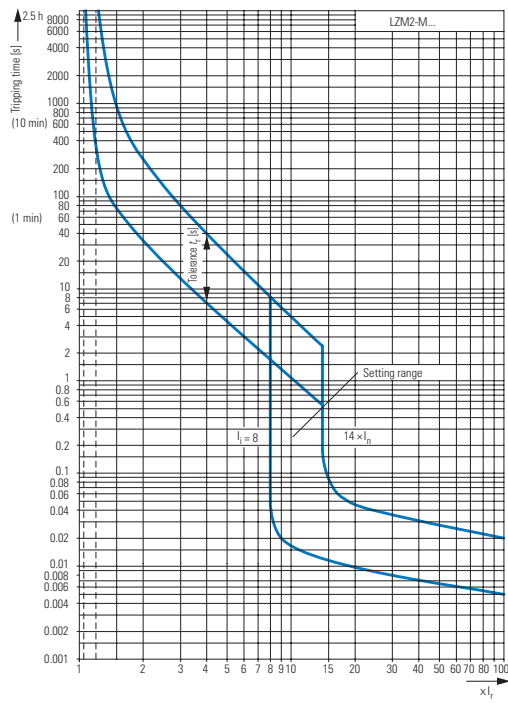

Motor protection with LZM3

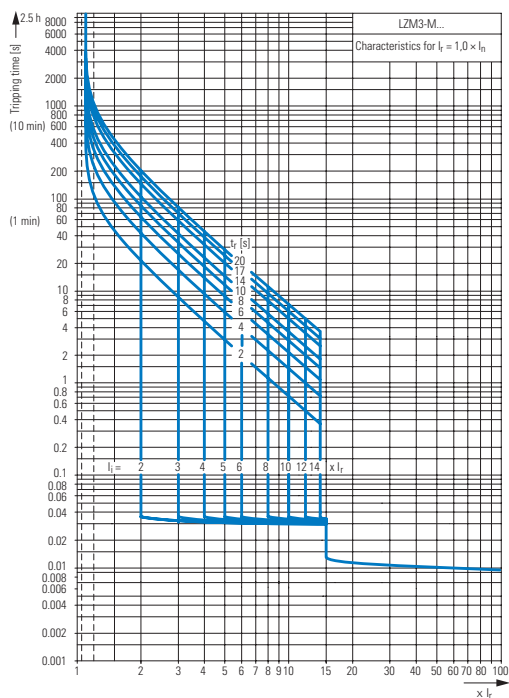

Motor protection with LZM4

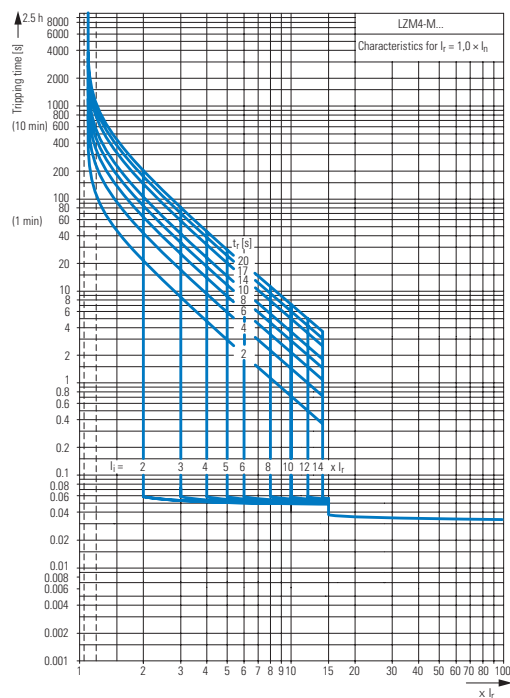

PKZM0 & PKZM4 Motor-protective circuit breakers

Technical specifications	PKZM0	PKZM4
General		
Standard	IEC/EN 60947, VDE0660, UL508, CSA C22.2 No.14	
Ambient temperature (Open) (°C)	-25 / 50	-25 / 50
Degree of protection	Front	Front
Rated operation voltage U_e	IP20	IP20
Rated conditional short-circuit current I_q (VAC)	690	690
Single-phasing sensitivity to IEC947-4-1	Yes	Yes
Switching capacity (KA)	150 / 50	50
Electrical Life span (AC-3 at 400VAC) (Operations)	100,000	30,000
Mechanical life span (Operations)	100,000	30,000

Motor-protective circuit-breaker tripping characteristic for PKZM0 & PKZM4

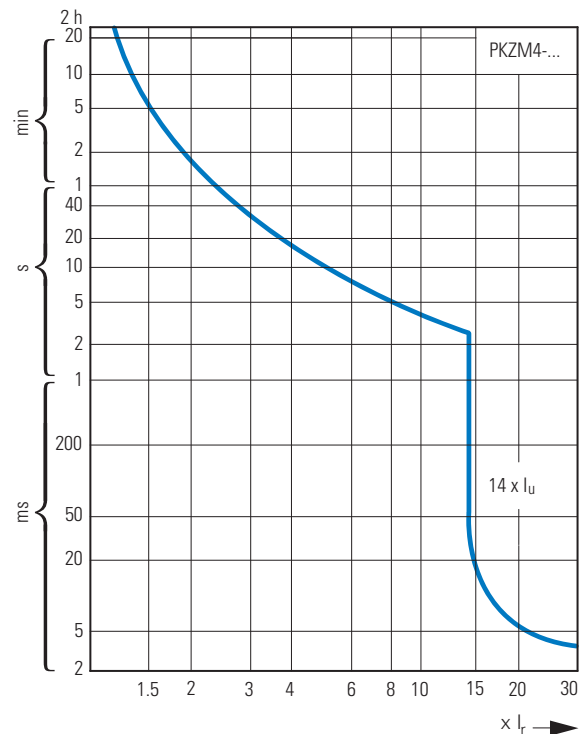
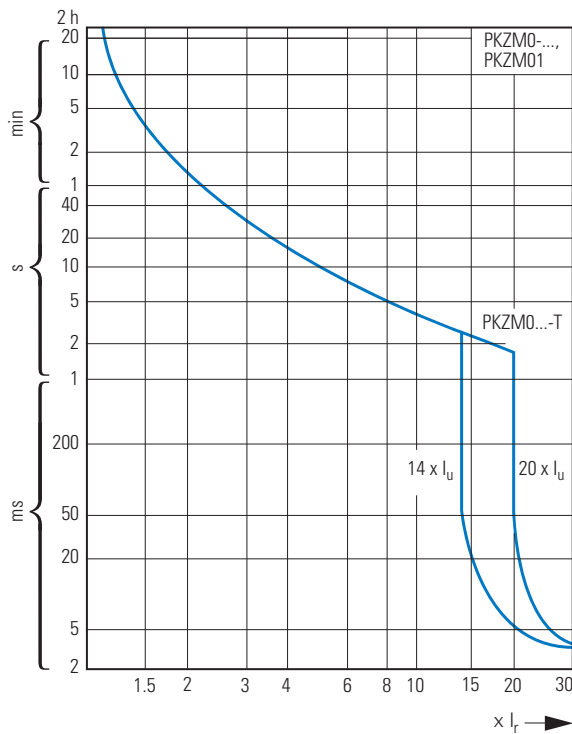

Electrical Sector Asia Pacific
 No.3, Lane 280, Linhong Road,
 Changning District, Shanghai

Eaton Industries Pte Ltd
 Electrical Sector
 4 Loyang Lane #04-01/02
 Singapore 508914
www.eaton.com/seasia-electrical

© 2013 Eaton Corporation
 All Rights Reserved
 Printed in Singapore
 xStart-SEA-EN
 July 2013

Eaton is a registered trademark
 of Eaton Corporation.

All trademarks are property of their
 respective owners.

Start easily, protect precisely



Powering Business Worldwide

Control relays XTRD



Control relays XTRD

1

Contactors XTCD

2

Thermal overload relays XTOD

3

Contactors XTCD



Thermal overload relays XTOD





The D Line is the newest addition to Eaton's portfolio line of control components. With global ratings and a capacity of up to 85A, D Line is perfect for everyday power control applications. The D Line offers control relays, contactors, starters and thermal overload relays to match any need. Simple, but efficient control for applications including pumps, fans, compressors and more, D Line delivers reliable operation in a compact package.

Control relays XTRD

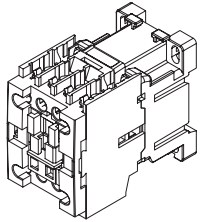

1.1 System overview	
Control relays XTRD	1
1.2 Control relays	
Basic devices XTRD	2
Auxiliary contact modules	3
1.3 Actuating voltages	
Control relays XTRD	4
1.4 Technical data	
Control relays XTRD	5
Auxiliary contact modules	5
1.5 Dimensions	
Control relays XTRD	6
Auxiliary contact modules	6

Control relays XTRD

Product Description

- Varied 4-pole contact configurations
- Conventional thermal current (I_{th}) of 10A
- DIN-rail or panel mount

Standards and Certifications

- GB 14048
- IEC/EN 60947
- CCC
- CE
- UL/CSA
(pending for availability)

System overview

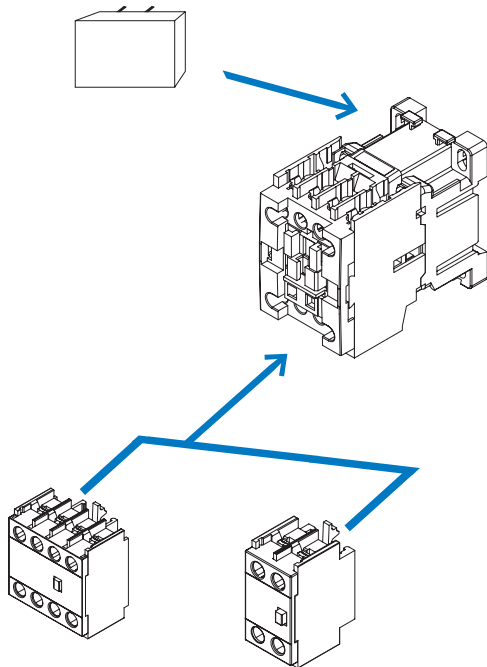

1.2

Control relays XTRD

Basic devices

1

XTRD

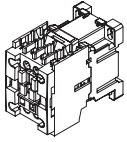

Control relays

Connection type	Contact		Rated operational current AC-15 /e (A)		Conventional thermal current, open, 55°C /th (A)	Circuit symbol	Can be combined with auxiliary contact module	AC operation	Standard package
	N/O=Normally open	N/C=Normally closed	220V	380 V				Part no.	
								Actuating voltage 220V 50/60HZ	
Screw terminals	4 N/O	-	3	1.9	10		XTCDXSAG11 XTCDXFAG..	XTRD10B40AO 152304	1 piece
Screw terminals	3 N/O	1 N/C	3	1.9	10		XTCDXSAG11 XTCDXFAG..	XTRD10B31AO 152297	1 piece
Screw terminals	2 N/O	2 N/C	3	1.9	10		XTCDXSAG11 XTCDXFAG..	XTRD10B22AO 152290	1 piece
Screw terminals	1 N/O	3 N/C	3	1.9	10		XTCDXSAG11 XTCDXFAG..	XTRD10B13AO 152283	1 piece
Screw terminals	-	4 N/C	3	1.9	10		XTCDXSAG11 XTCDXFAG..	XTRD10B04AO 152736	1 piece

Notes

With screw terminals

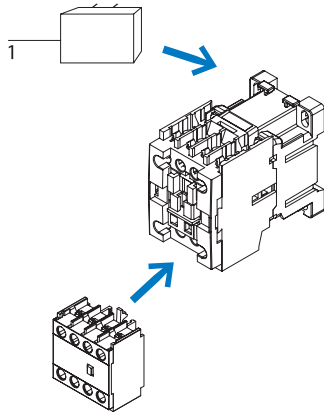

Accessories

- 1 Suppressor
- 2 Auxiliary contact module
- Actuating voltages

Page

- 2/8
- 1/4
- 1/4

Auxiliary contact modules

Auxiliary contact, top mounting

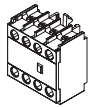

Auxiliary contact, side mounting



Connection type		Conventional thermal current open, 55°C $I_{th} = I_e$ AC-1 A	Contact N/O=Normally open N/C=Normal closed		Circuit symbol	Can be combined with control relay	Part no. Article no.	Standard package
Screw terminals	2 pole	10	2 N/O	-		XTRD10B..	XTCDXFAG20 152430	1 piece
Screw terminals	2 pole	10	1 N/O	1 N/C		XTRD10B..	XTCDXFAG11 152431	1 piece
Screw terminals	2 pole	10	-	2 N/C		XTRD10B..	XTCDXFAG02 152432	1 piece
Screw terminals	4 pole	10	4 N/O	-		XTRD10B..	XTCDXFAG40 152433	1 piece
Screw terminals	4 pole	10	3 N/O	1 N/C		XTRD10B..	XTCDXFAG31 152434	1 piece
Screw terminals	4 pole	10	2 N/O	2 N/C		XTRD10B..	XTCDXFAG22 152435	1 piece
Screw terminals	4 pole	10	1 N/O	3 N/C		XTRD10B..	XTCDXFAG13 152436	1 piece
Screw terminals	4 pole	10	-	4 N/C		XTRD10B..	XTCDXFAG04 152437	1 piece
Screw terminals	2 pole	10	1 N/O	1 N/C		XTRD10B..	XTCDXSAG11 152438	1 piece

Actuating voltages AC

Standard coil 50/60Hz	Coil Suffix	XTRD10B40.. Article no. ¹⁾	XTRD10B31.. Article no. ¹⁾	XTRD10B22.. Article no. ¹⁾	XTRD10B13.. Article no. ¹⁾	XTRD10B04.. Article no. ¹⁾
24V	B2	152306	152299	152292	152285	151738
48V	C2	152307	152300	152293	152286	151739
110V	E2	152309	152302	152295	152288	152281
220V	A0	152304	152297	152290	152283	151736
240V	H2	152310	152303	152296	152289	152282
380V	AR	152305	152298	152291	152291	151737
440V	DQ	152308	152301	152294	152287	152280

¹⁾The full part no. consists of basic type and coil suffix.

1.4

Control relays XTRD

Technical data

1

General

			XTRD	XTCDXFAG	XTCDXSAG
Standards			IEC/EN 60947, GB 14048		
Mechanical lifespan					
AC operated	Operations	x 10 ⁶	5	5	5
Maximum operating frequency					
Maximum operating frequency	Operations/h		1200	1200	1200
Climatic proofing			Damp heat, constant, to IEC 60068-2-78 Damp heat, cyclic, to IEC 60068-2-30		
Ambient temperature					
Operation		°C	-20-55	-20-55	-20-55
Storage		°C	-40-80	-40-80	-40-80
Mounting position			Have the angle of ±30° with normal vertical installation plane		

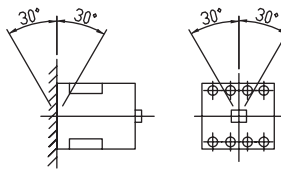

Protection type			IP20	IP20	IP20
Weight	Approximate weight	kg	0.3	0.3	0.3
Terminal capacity					
Solid		mm ²	1 x (1-6) 2 x (1-6)	1 x (1-6) 2 x (1-6)	1 x (1-6) 2 x (1-6)
Flexible with ferrule		mm ²	1 x (1-4) 2 x (1-4)	1 x (1-4) 2 x (1-4)	1 x (1-4) 2 x (1-4)
Solid or stranded		AWG			
Terminal screw			M3.5	M3.5	M3.5
Max tightening torque		Nm	0.8	0.8	0.8

Contacts

Rated impulse withstand voltage	U_{imp}	VAC	6000	6000	6000
Oversvoltage category/degree of pollution			III/3	III/3	III/3
Rated insulation voltage AC	U_i	VAC	1000	690	690
Rated operational voltage	U_e	VAC	690	600	600
Rated operational current					

AC-15

120V	I_e	A	6	6	6
220/240V	I_e	A	3	3	3
380V	I_e	A	1.9	1.9	1.9
480V	I_e	A	1.5	1.5	1.5
500V	I_e	A	1.4	1.4	1.4
600V	I_e	A	1.2	1.2	1.2

DC-13

125V	I_e	A	0.55	0.55	0.55
250V	I_e	A	0.27	0.27	0.27
Conventional thermal current	I_{th}	A	10	10	10

Electrical lifespan

at $U_e=230V$, AC-15, 3A	Operations	x 10 ⁶	1	1	1
---------------------------	------------	-------------------	---	---	---

Magnet system

			XTRD	XTCDXFAG	XTCDXSAG
Voltage tolerance					
AC operated	Pick-up	$x U_c$	0.75-1.1	0.75-1.1	0.75-1.1
Power consumption	Pick-up	VA	70	70	70
	Sealing	VA	12	12	12
	Sealing	W	3.5	3.5	3.5
Duty factor		% DF	40	40	40

Dimensions

Control relay (with XTCDXFAG)

XTRD10B

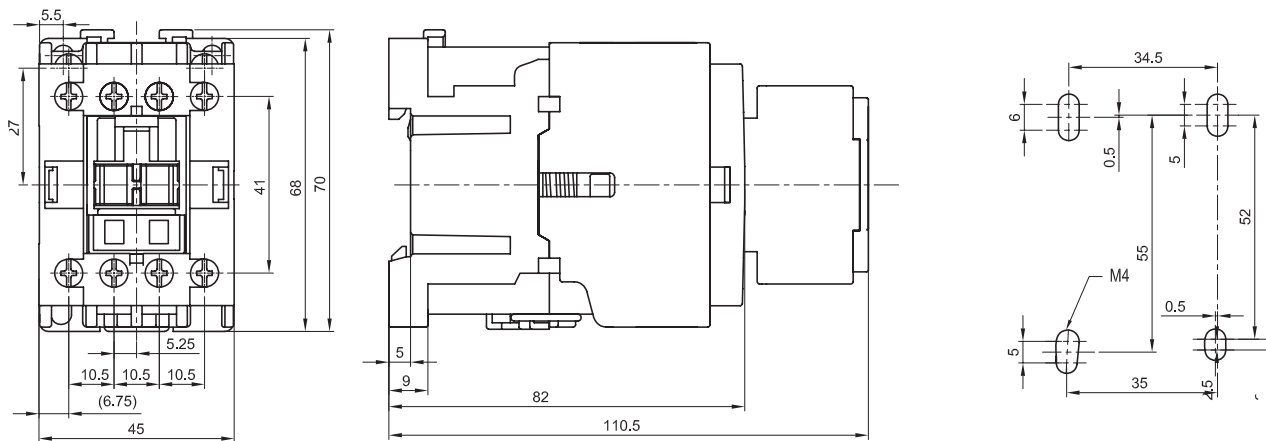

Auxiliary contact module, top mousing

XTCDXFAG(2P)

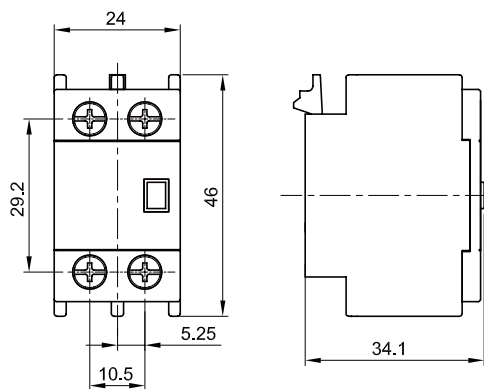

Auxiliary contact module, top mousing

XTCDXFAG(4P)

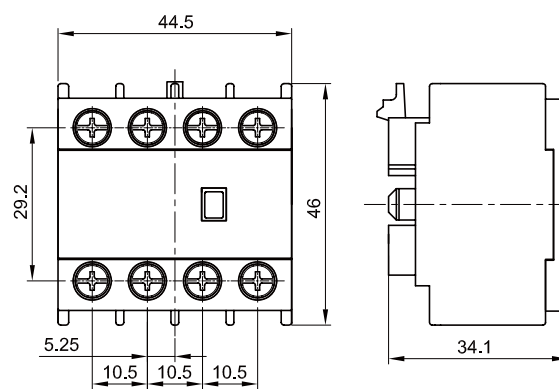

Contactors XTCD

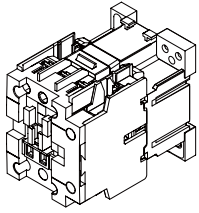

2.1	System overview	
	Contactors XTCD.....	8
2.2	Contactors	
	Basic devices XTCD	10
	Auxiliary contact modules	13
2.3	Accessories	
	Contactors XTCD	14
2.4	Actuating voltages	
	Contactors XTCD.....	15
	Spare coils.....	16
2.5	Characteristic curves	
	Contactors XTCD.....	17
2.6	Technical data	
	Contactors XTCD	18
	Auxiliary contact modules	22
2.7	Dimensions	
	Contactors XTCD	23
	Auxiliary contact modules	25
	Accessories	26

Contactors XTCD

Product Description

- 6 frame sizes with current ranges from 7-85A@ AC-3,400V
- Built-in auxiliary contacts on all frames
- Add-on auxiliary contacts for all frames
- Wide range of control voltages from 24-440V in dual frequency 50/60Hz
- Wide selection of accessories for all frames

Standards and Certifications

- GB 14048
- IEC/EN 60947
- CCC
- CE
- UL/CSA
(pending for availability)

2.1

Contactors XTCD System overview

System overview



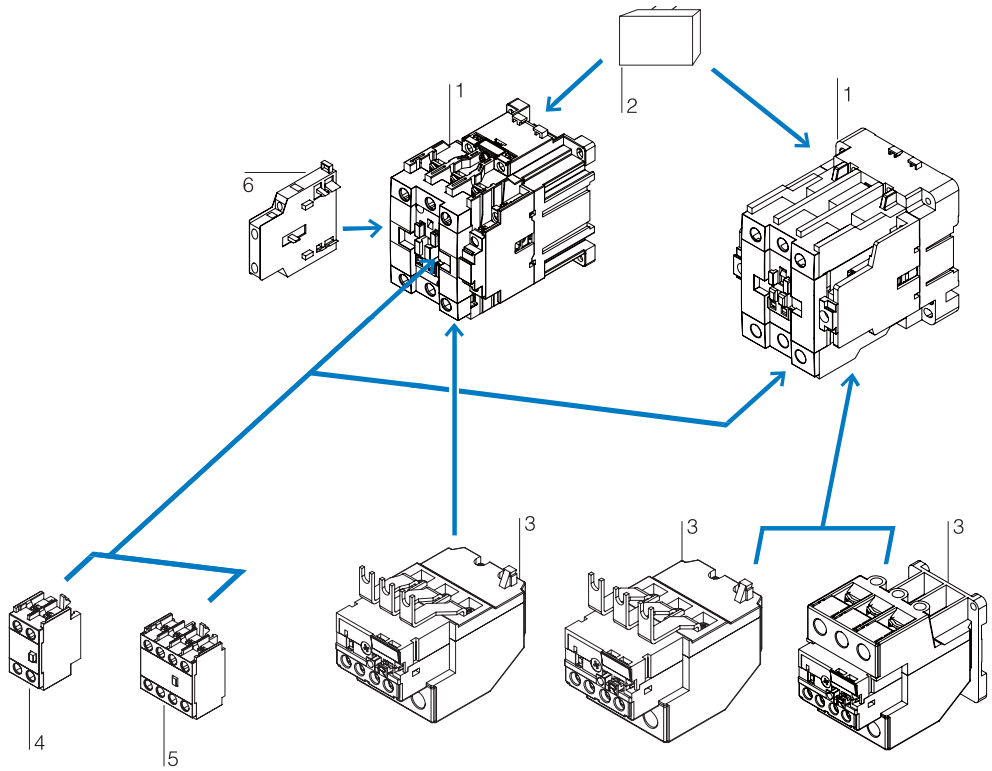
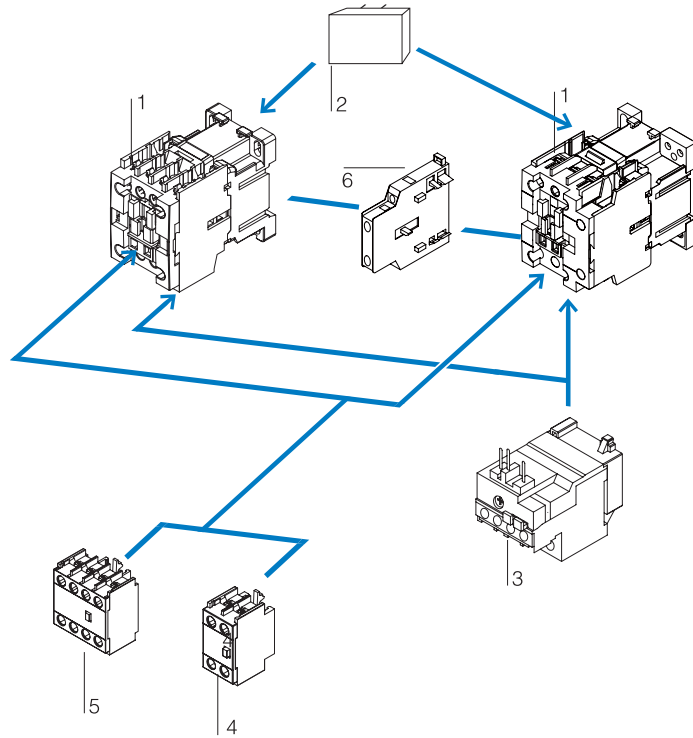







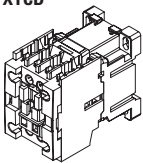



2

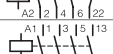

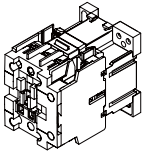
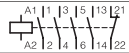
System overview

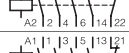
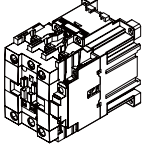
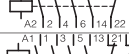
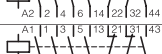
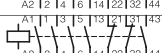
Contactor, to 45kW (AC-3/400V)	1	Thermal overload relay	3	Auxiliary contact module	5
Magnet system :		Direct mounting		4 pole, top mounting	
AC: 24V, 48V, 110V, 220V, 240V, 380V, 440V		Separate mounting			
		→ 3/1		→ 2/6	
→ 2/4					
Surge suppressor	2	Auxiliary contact module	4	Auxiliary contact module	6
RC suppressor		2 pole, top mounting		2 pole, side mounting	
Variastor suppressor					
		→ 2/6		→ 2/6	
→ 2/8					

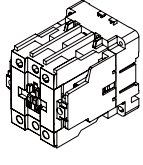
3-pole contactors

Can be combined with auxiliary contact module	Connection type	Rated operational current AC-3 I _e (A)		Max motor rating for 3-phase motors, 50-60Hz AC-3 P kW			Conventional thermal current, open, 55 °C /I _{th} = I _e AC-1(A)	Contact N/O=Normally open N/C=Normal closed	Circuit symbol	AC operation Part no. Article no. Actuating voltage 220V 50/60Hz
		380V	400V	220V 230V	380V 400V	660V 690V				
	Screw terminals	7		2.2	3	3.5	25	1 N/O -		XTCD007B10A0 152318
	Screw terminals	7		2.2	3	3.5	25	1 N/C		XTCD007B01A0 152311
	Screw terminals	9		2.5	4	4.5	25	1 N/O -		XTCD009B10A0 152332
	Screw terminals	9		2.5	4	4.5	25	1 N/C		XTCD009B01A0 152325
	Screw terminals	12		3	5.5	5.5	25	1 N/O -		XTCD012B10A0 152346
	Screw terminals	12		3	5.5	5.5	25	1 N/C		XTCD012B01A0 152339
	Screw terminals	16		4	7.5	7.5	25	1 N/O -		XTCD016B10A0 152360
	Screw terminals	16		4	7.5	7.5	25	1 N/C		XTCD016B01A0 152353
	Screw terminals	22		5.5	11	11	32	1 N/O 1 N/C		XTCD022C11A0 152367
	Screw terminals	26		7.5	11	11	35	1 N/O 1 N/C		XTCD026C11A0 152374
	Screw terminals	32		7.5	15	18.5	50	1 N/O 1 N/C		XTCD032D11A0 152381
	Screw terminals	38		11	18.5	22	60	1 N/O 1 N/C		XTCD038E11A0 152388
	Screw terminals	40		11	20	22	60	1 N/O 1 N/C		XTCD040F11A0 152395
	Screw terminals	55		15	25	30	70	2 N/O 2 N/C		XTCD055G22A0 152402
	Screw terminals	64		18.5	30	37	80	2 N/O 2 N/C		XTCD065G22A0 152409
	Screw terminals	72		22	37	45	100	2 N/O 2 N/C		XTCD072G22A0 152416
	Screw terminals	85		25	45	45	135	2 N/O 2 N/C		XTCD085G22A0 152423

Standard package: 1piece

Can be combined with auxiliary contact module	AC operation Part no. Article no. Actuating voltage 220V 50/60Hz	Standard package
XTCDXFAG20	XTCD007B10AO 152318	1
XTCDXFAG11	XTCD007B01AO 152311	1
XTCDXFAG02	XTCD009B10AO 152332	1
XTCDXFAG40	XTCD009B01AO 152325	1
XTCDXFAG31	XTCD012B10AO 152346	1
XTCDXFAG22	XTCD012B01AO 152339	1
XTCDXFAG13	XTCD016B10AO 152360	1
XTCDXFAG04	XTCD016B01AO 152353	1
XTCDXSAG11	XTCD022C11AO 152367	1
	XTCD026C11AO 152374	1
	XTCD032D11AO 152381	1
	XTCD038E11AO 152388	1
	XTCD040F11AO 152395	1
	XTCD055G22AO 152402	1
	XTCD065G22AO 152409	1
	XTCD072G22AO 152416	1
	XTCD085G22AO 152423	1

Notes

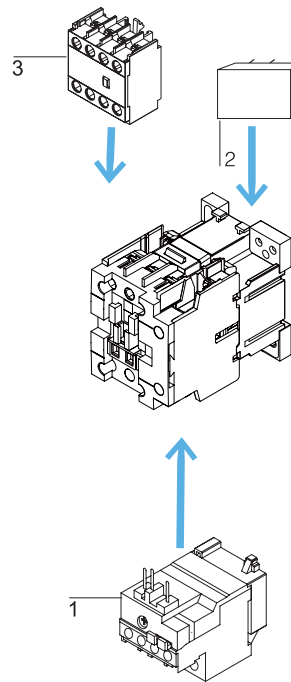

Accessories

- 1 Overload relay → 3/2
- 2 Suppressor → 2/1
- 3 Auxiliary contact module → 2/6
- Actuating voltages → 2/9
- Other accessories → 2/8

2.2

Contactors XTCD Basic devices

2

Auxiliary contact modules

Auxiliary contact, top mounting

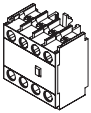

Auxiliary contact, side mounting

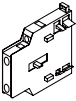

Can be combined with control relay	Connection type		Conventional thermal current, open, 55 °C $I_{th} = I_e$ AC-1(A)	Contact N/O=Normally open N/C=Normal closed		Circuit symbol	Part no. Article no.	Standard package
XTCD007	Screw terminals	2 pole	10	2 N/O	-		XTCDXFAG20 152430	1 piece
XTCD009	Screw terminals	2 pole	10	1 N/O	1 N/C		XTCDXFAG11 152431	1 piece
XTCD012	Screw terminals	2 pole	10	-	2 N/C		XTCDXFAG02 152432	1 piece
XTCD016	Screw terminals	2 pole	10	-	2 N/C		XTCDXFAG02 152432	1 piece
XTCD022	Screw terminals	2 pole	10	-	2 N/C		XTCDXFAG02 152432	1 piece
XTCD026	Screw terminals	2 pole	10	-	2 N/C		XTCDXFAG02 152432	1 piece
XTCD032	Screw terminals	4 pole	10	4 N/O	-		XTCDXFAG40 152433	1 piece
XTCD038	Screw terminals	4 pole	10	4 N/O	-		XTCDXFAG40 152433	1 piece
XTCD040	Screw terminals	4 pole	10	3 N/O	1 N/C		XTCDXFAG31 152434	1 piece
XTCD055	Screw terminals	4 pole	10	3 N/O	1 N/C		XTCDXFAG31 152434	1 piece
XTCD065	Screw terminals	4 pole	10	2 N/O	2 N/C		XTCDXFAG22 152435	1 piece
XTCD072	Screw terminals	4 pole	10	2 N/O	2 N/C		XTCDXFAG22 152435	1 piece
XTCD085	Screw terminals	4 pole	10	1 N/O	3 N/C		XTCDXFAG13 152436	1 piece
XTCD085	Screw terminals	4 pole	10	-	4 N/C		XTCDXFAG04 152437	1 piece
XTCD007	Screw terminals	2 pole	10	1 N/O	1 N/C		XTCDXSAG11 152438	1 piece
XTCD009	Screw terminals	2 pole	10	1 N/O	1 N/C		XTCDXSAG11 152438	1 piece
XTCD012	Screw terminals	2 pole	10	-	-			
XTCD016	Screw terminals	2 pole	10	-	-			
XTCD022	Screw terminals	2 pole	10	-	-			
XTCD026	Screw terminals	2 pole	10	-	-			
XTCD032	Screw terminals	4 pole	10	-	-			
XTCD038	Screw terminals	4 pole	10	-	-			
XTCD040	Screw terminals	4 pole	10	-	-			

Auxiliary contact modules

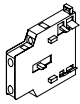

XTCDXSAG11

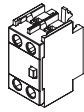

XTCDXFAG20
XTCDXFAG11
XTCDXFAG02

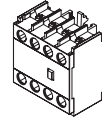

XTCDXFAG40
XTCDXFAG31
XTCDXFAG22
XTCDXFAG13
XTCDXFAG04

XTCD007	1x	-	-
XTCD009	-	1x	-
XTCD012	-	-	1x
XTCD016	-	-	-
XTCD022	-	-	-
XTCD026	-	-	-
XTCD032	-	-	-
XTCD038	-	-	-
XTCD040	-	-	-
XTCD055	-	1x	-
XTCD065	-	-	1x
XTCD072	-	-	-
XTCD085	-	-	-

Auxiliary contact, side mounting

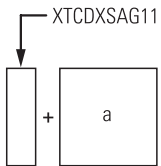

a XTCD007 - XTCD040

RC suppressors



Surge suppressors

For use with	Voltage V	Circuit symbol	Part no. Article no.	Standard package	Note
XTCD007 XTCD009 XTCD012	24		XTCDXRSGB2 152441	1 piece	Note release delay
XTCD016 XTCD022 XTCD026 XTCD032 XTCD038	48		XTCDXRSGC2 152442	1 piece	Note release delay
XTCD040 XTCD055 XTCD065 XTCD072 XTCD085	110		XTCDXRSGE2 152443	1 piece	Note release delay
	220-240		XTCDXRSGH2 152444	1 piece	Note release delay
	440		XTCDXRSGDQ 152445	1 piece	Note release delay
XTCD007 XTCD009 XTCD012	24		XTCDXVSGB2 152446	1 piece	Note release delay
XTCD016 XTCD022 XTCD026 XTCD032 XTCD038	48		XTCDXVSGC2 152447	1 piece	Note release delay
XTCD040 XTCD055 XTCD065 XTCD072 XTCD085	110		XTCDXVSGE2 152448	1 piece	Note release delay
	220-240		XTCDXVSGH2 152449	1 piece	Note release delay
	440		XTCDXVSGDQ 152450	1 piece	Note release delay

Varistor suppressors



Mechanical interlocks

For use with	Part no. Article no.	Standard package
XTCD007 XTCD009 XTCD012 XTCD016 XTCD022 XTCD026 XTCD032	XTCDXMLD 152439	1 piece
XTCD038 XTCD040 XTCD055 XTCD065 XTCD072 XTCD085	XTCDXMLG 152440	1 piece

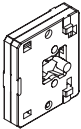
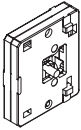

Spare coils

For use with	Part no. Article no.	Standard package
	Actuating voltage 220V 50/60Hz	
XTCD007 XTCD009 XTCD012 XTCD016 XTCD022 XTCD026 XTCD032	XTCDRENCOILDAO 152451	1 piece
XTCD038	XTCDRENCOILEAO 152458	1 piece
XTCD040	XTCDRENCOILFAO 152465	1 piece
XTCD055 XTCD065 XTCD072 XTCD085	XTCDRENCOILGAO 152472	1 piece

Actuating voltages AC

Standard coil 50/60Hz	Coil Suffix	XTCD007B10.. Article no. ¹⁾	XTCD007B01.. Article no. ¹⁾	XTCD009B10.. Article no. ¹⁾	XTCD009B01.. Article no. ¹⁾	XTCD012B10.. Article no. ¹⁾	XTCD012B01.. Article no. ¹⁾	XTCD016B10.. Article no. ¹⁾
24V	B2	152320	152313	152334	152327	152348	152341	152362
48V	C2	152321	152314	152335	152328	152349	152342	152363
110V	E2	152323	152316	152337	152330	152351	152344	152365
220V	A0	152318	152311	152332	152325	152346	152339	152360
240V	H2	152324	152317	152338	152331	152352	152345	152366
380V	AR	152319	152312	152333	152326	152347	152340	152361
440V	DQ	152322	152315	152336	152329	152350	152343	152364

Standard coil 50/60Hz	Coil Suffix	XTCD016B01.. Article no. ¹⁾	XTCD022C11.. Article no. ¹⁾	XTCD026C11.. Article no. ¹⁾	XTCD032D11.. Article no. ¹⁾	XTCD038E11.. Article no. ¹⁾	XTCD040F11.. Article no. ¹⁾	XTCD052G22.. Article no. ¹⁾
24V	B2	152355	152369	152376	152383	152390	152397	152404
48V	C2	152356	152370	152377	152384	152391	152398	152405
110V	E2	152358	152372	152379	152386	152393	152400	152407
220V	A0	152353	152367	152374	152381	152388	152395	152402
240V	H2	152359	152373	152380	152387	152394	152401	152408
380V	AR	152354	152368	152375	152382	152389	152396	152403
440V	DQ	152357	152371	152378	152385	152392	152399	152406

Standard coil 50/60Hz	Coil Suffix	XTCD065G22.. Article no. ¹⁾	XTCD072G22.. Article no. ¹⁾	XTCD085G22.. Article no. ¹⁾
24V	B2	152411	152418	152425
48V	C2	152412	152419	152426
110V	E2	152414	152421	152428
220V	A0	152409	152416	152423
240V	H2	152415	152422	152429
380V	AR	152410	152417	152424
440V	DQ	152413	152420	152427

¹⁾The full part no. consists of basic type and coil suffix.

2.4

Contactors XTCD Spare coils

Spare coils AC

2

Standard coil 50/60Hz	Coil Suffix	XTCDRENCOILD.. Article no. ¹⁾	XTCDRENCOILE.. Article no. ¹⁾	XTCDRENCOILF.. Article no. ¹⁾	XTCDRENCOILG.. Article no. ¹⁾
24V	B2	152453	152460	152467	152474
48V	C2	152454	152461	152468	152475
110V	E2	152456	152463	152470	152477
220V	A0	152451	152458	152465	152472
240V	H2	152457	152464	152471	152478
380V	AR	152452	152459	152466	152473
440V	DQ	152455	152462	152469	152476

¹⁾ The full part no. consists of basic type and coil suffix.

Normal switching duty

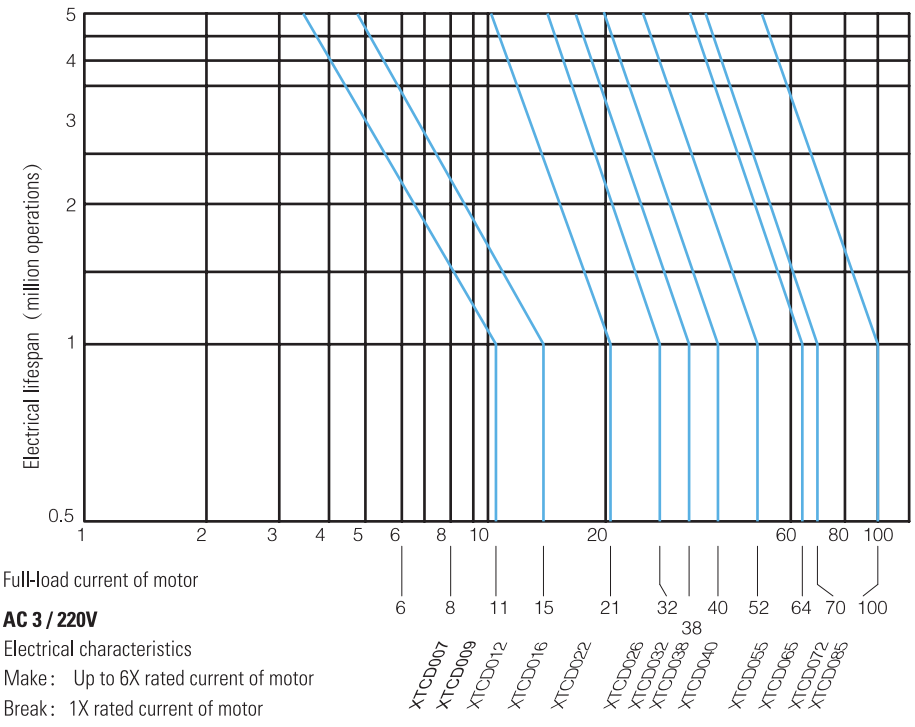
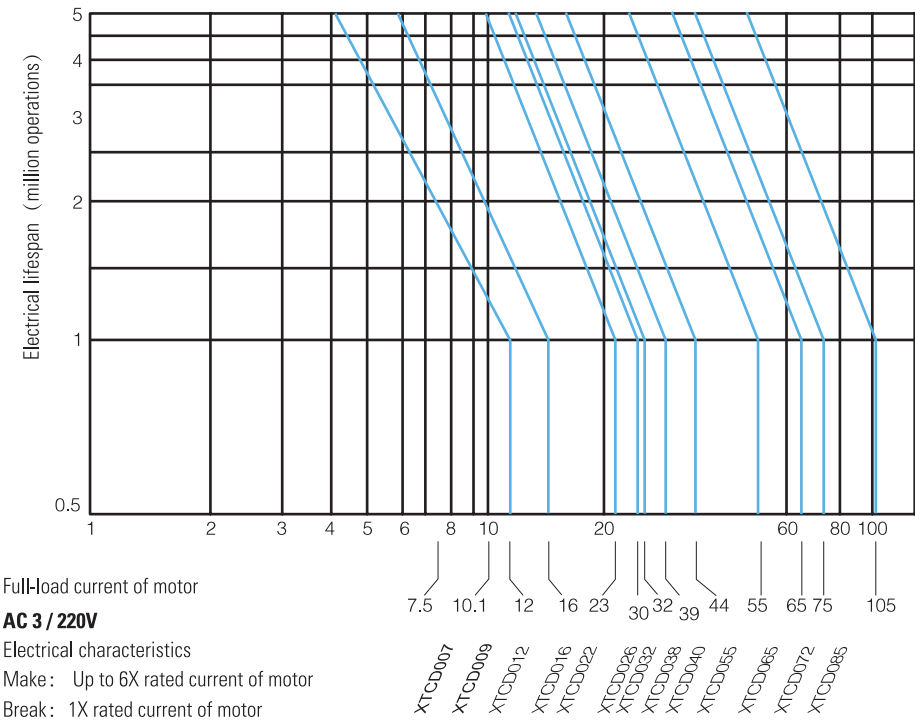

General

2

XT Basic device			CD007	CD009	CD012	CD016	CD022
Standards			IEC/EN 60947, GB 14048				
Lifespan, mechanical							
AC operated	Operations	x 10 ⁶	5	5	5	5	5
Operating frequency, mechanical							
AC operated	Operations/h		1200	1200	1200	1200	1200
Climatic Proofing			Damp heat, constant, to IEC60068-2-78 Damp heat, cyclic, to IEC60068-2-30				
Ambient temperature							
Operation		°C	-20~55	-20~55	-20~55	-20~55	-20~55
Storage		°C	-40~80	-40~80	-40~80	-40~80	-40~80
Mounting position			Have the angle of ± 30° with normal vertical installation plane				

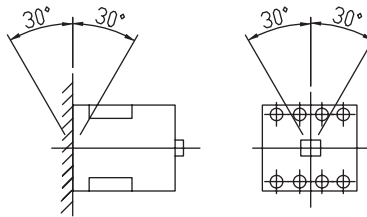

Protection type			IP20	IP20	IP20	IP20	IP20
Weight			kg	0.3	0.3	0.3	0.4
Terminal capacity of main cable							
Solid			mm ²	1 x (1.5-6) 2 x (1.5-6)	1 x (1.5-6) 2 x (1.5-6)	1 x (1.5-6) 2 x (1.5-6)	1 x (2.5-10) 2 x (2.5-10)
Flexible with ferrule			mm ²	1 x (1.5-4) 2 x (1.5-4)	1 x (1.5-4) 2 x (1.5-4)	1 x (1.5-4) 2 x (1.5-4)	1 x (2.5-6) 2 x (2.5-6)
Solid/stranded			AWG				
Terminal capacity of control circuit cable			mm ²	1	1	1	1
Main cable connection screws / bolts				M3.5	M3.5	M3.5	M4
Tightening torque			Nm	0.8	0.8	0.8	1.2
Control circuit cable connection screws / bolts				M3.5	M3.5	M3.5	M3.5
Tightening torque			Nm	0.8	0.8	0.8	0.8

Main contacts

Rated impulse withstand voltage		U_{imp}	V AC	6000	6000	6000	6000	6000
Overvoltage category / pollution degree				I/3	III/3	III/3	III/3	III/3
Rated insulation voltage		U_i		1000	1000	1000	1000	1000
Rated operational voltage		U_e		690	690	690	690	690
Making capacity ($\cos \phi$ to IEC/EN60947)		A	to 690 V	60	60	60	60	140
Breaking capacity ($\cos \phi$ to IEC/EN60947)								
	220V/230V	A		92	92	96	128	184
	380V/400V	A		88	88	96	128	176
	500V	A		64	64	72	104	152
	660V/690V	A		48	48	56	80	112
Electrical lifespan								
	/ _e AC-3 400V	x 10 ⁶	Op.	1	1	1	1	1
Maximum operating frequency								
	/ _e AC-3 400V		Op./h	1200	1200	1200	1200	1200

CD026	CD032	CD038	CD040	CD055	CD065	CD072	CD085
IEC/EN 60947, GB 14048							
5	5	5	5	5	5	5	5
1200	1200	1200	1200	1200	1200	1200	1200
Damp heat, constant, to IEC60068-2-78							
Damp heat, cyclic, to IEC60068-2-30							
-20-55	-20-55	-20-55	-20-55	-20-55	-20-55	-20-55	-20-55
-40-80	-40-80	-40-80	-40-80	-40-80	-40-80	-40-80	-40-80
IP20	IP20	IP20	IP20	IP20	IP20	IP00	IP00
0.4	0.7	0.7	0.9	1.3	1.3	1.3	1.3
1 x (2.5-10) 2 x (2.5-10)	1 x (2.5-16) 2 x (2.5-16)	1 x (2.5-16) 2 x (2.5-16)	1 x (4-16) 2 x (4-16)	1 x (10-50) 2 x (10-50)	1 x (10-50) 2 x (10-50)	1 x (10-50) 2 x (10-50)	1 x (10-50) 2 x (10-50)
1 x (2.5-6) 2 x (2.5-6)	1 x (2.5-10) 2 x (2.5-10)	1 x (2.5-10) 2 x (2.5-10)	1 x (2.5-10) 2 x (2.5-10)	1 x (6-35) 2 x (6-35)	1 x (6-35) 2 x (6-35)	1 x (6-35) 2 x (6-35)	1 x (6-35) 2 x (6-35)
1	1	1	1	1	1	1	1
M4	M5	M5	M5	M6	M6	M6	M6
1.2	2.0	2.0	2.0	3.0	3.0	3.0	3.0
M3.5	M3.5	M3.5	M3.5	M3.5	M3.5	M3.5	M3.5
0.8	0.8	0.8	0.8	0.8	0.8	0.8	0.8
6000	6000	6000	6000	6000	6000	6000	6000
III/3	III/3	I/3	III/3	III/3	III/3	III/3	III/3
1000	1000	1000	1000	1000	1000	1000	1000
690	690	690	690	690	690	690	690
140	220	242	260	350	450	600	650
216	280	312	352	440	520	600	680
208	256	304	320	440	512	576	680
152	140	264	280	360	440	520	640
112	176	176	208	280	360	480	520
1	1	1	1	1	1	1	1
1200	1200	1200	1200	1200	1200	1200	1200

2.6

Contactors XTCD Technical data

AC voltage

2

XT Basic device				CD007	CD009	CD012	CD016	CD022
AC-1 operation								
Conventional thermal current, open, 50-60 Hz, 3 pole	at 40 °C	I_{th}	A	25	25	25	25	35
	at 50 °C	I_{th}	A	25	25	25	25	32
	at 55 °C	I_{th}	A	25	25	25	25	32
AC-3 operation								
Rated operational current, open, 50-60 Hz, 3 pole	220/230V	I_e	A	7	9	12	16	23
	380/400V	I_e	A	7	9	12	16	22
	415V	I_e	A	7	9	11	15	21
	440V	I_e	A	7	9	11	15	21
	500V	I_e	A	7	8	9	13	19
	660/690V	I_e	A	4	5	7	10	14
Rated operational power	220/230V	P	kW	2.2	2.5	3	4	5.5
	380/400V	P	kW	3	4	5.5	7.5	11
	415V	P	kW	3	4	5.5	7.5	11
	440V	P	kW	3	4	5.5	7.5	11
	500V	P	kW	3	4	5.5	7.5	11
	660/690V	P	kW	3.5	4.5	5.5	7.5	11

Magnet systems

Voltage tolerance								
AC operated	Pick-up	$x U_c$		0.7-1.1	0.7-1.1	0.7-1.1	0.7-1.1	0.7-1.1
Power consumption of coil in a cold state and $1.0 \times U_c$								
	Pick-up	VA		70	70	70	70	70
	Sealing	VA		13	12	12	12	12
	Sealing	W		3.5	3.5	3.5	3.5	3.5
Duty factor		%DF		40	40	40	40	40

CD026	CD032	CD038	CD03840	CD055	CD065	CD072	CD085
40	60	60	60	70	80	100	135
35	50	60	60	70	80	100	135
35	50	60	60	70	80	100	135
27	32	39	42	55	65	75	85
26	32	38	40	55	64	72	85
21	32	38	40	52	64	72	85
21	32	38	40	52	64	70	85
19	30	33	35	45	55	65	80
14	22	24	26	35	45	60	65
7.5	7.5	11	11	15	18.5	22	25
11	15	18.5	20	25	30	37	45
11	15	22	22	25	33	40	45
11	15	22	22	30	37	40	51
11	18.5	22	22	30	37	45	55
11	18.5	22	22	30	37	45	55

0.7-1.1	0.7-1.1	0.75-1.1	0.75-1.1	0.75-1.1	0.75-1.1	0.75-1.1	0.75-1.1
70	70	215	215	280	280	280	280
12	12	27	27	32	32	32	32
3.5	3.5	6	6	6	6	6	6
40	40	40	40	40	40	40	40

2.6

Contactors XTCD

Technical data of auxiliary contact modules

Auxiliary contact

2

			XTCDFAG	XTCDXSAG
Rated impulse withstand voltage	U_{imp}	VAC	6000	6000
Overvoltage category/degree of pollution			III/3	III/3
Rated insulation voltage	U_i	VAC	690	690
Rated operational voltage	U_e	VAC	600	600
Rated operational current				
AC-15				
120V	I_e	A	6	6
220/240V	I_e	A	3	3
380V	I_e	A	1.9	1.9
480V	I_e	A	1.5	1.5
500V	I_e	A	1.4	1.4
600V	I_e	A	1.2	1.2
DC-13				
125V	I_e	A	0.55	0.55
250V	I_e	A	0.27	0.27
Conventional thermal current	I_{th}	A	10	10
Electrical lifespan				
at $U_e=230V$, AC-15, 3A	Operations	$\times 10^6$	1	1

Dimensions

Contactor (with XTCDXFAG)
 XTCD007B
 XTCD009B
 XTCD012B
 XTCD016B

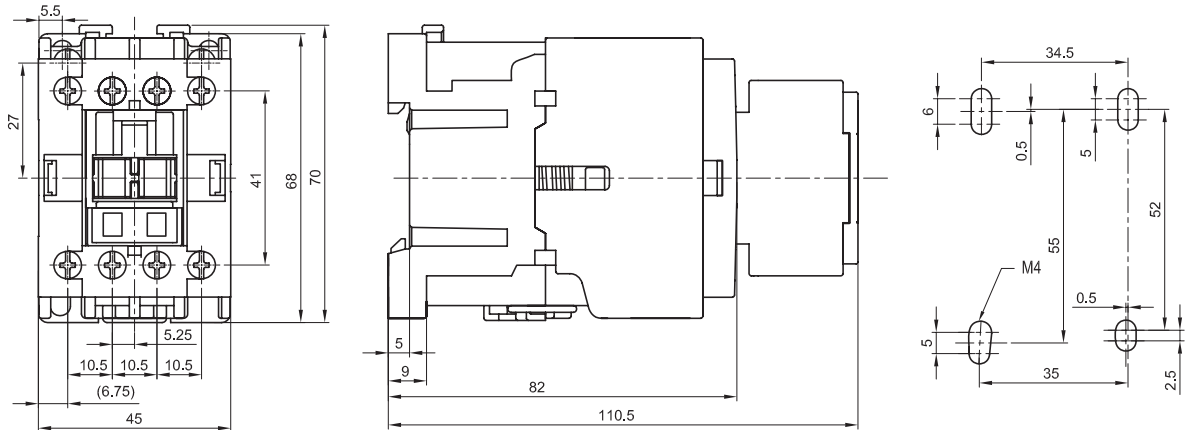

XTCD022C
 XTCD026C

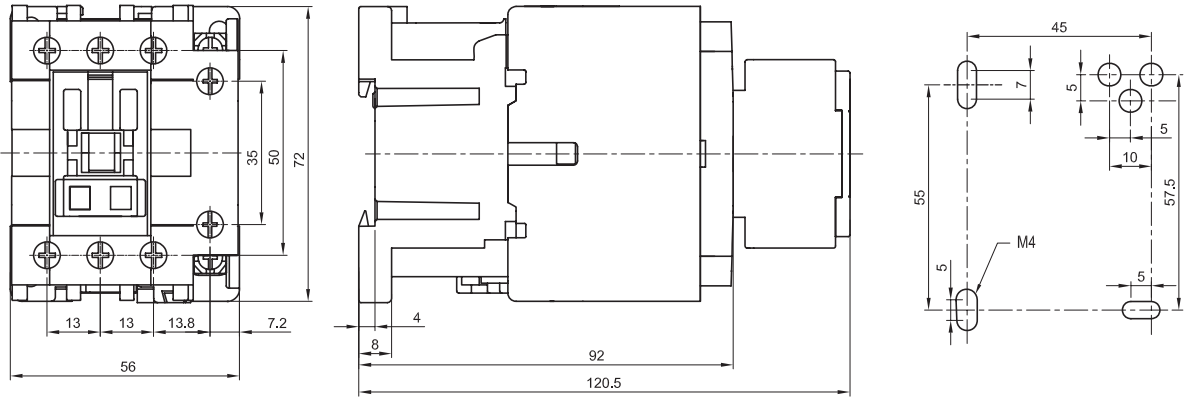

XTCD032D

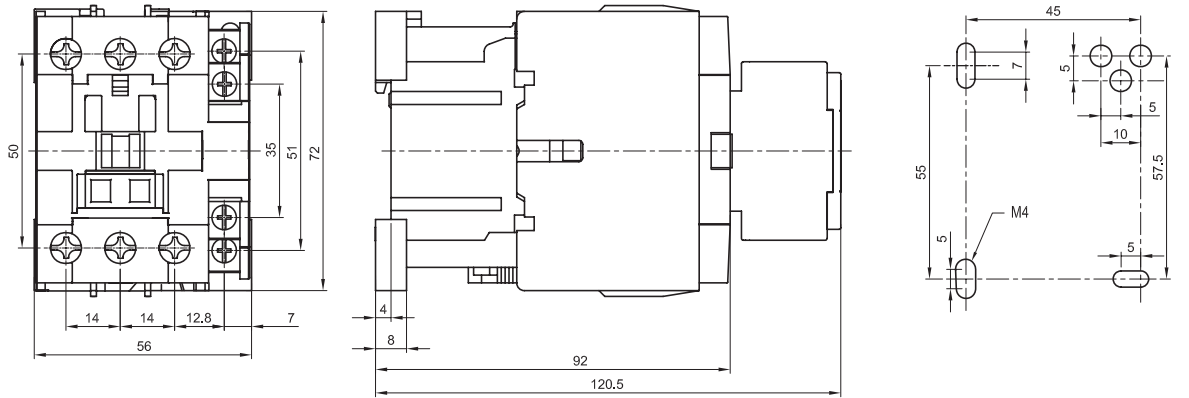

2.7 Contactors XTCD

Dimensions

Dimensions

XTCD038E

2

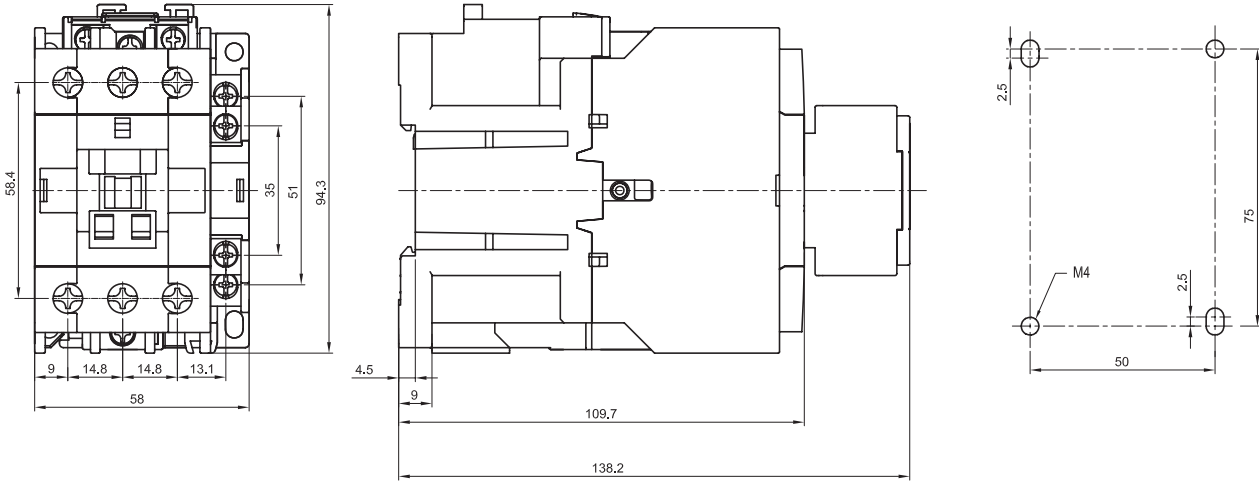

XTCD040F

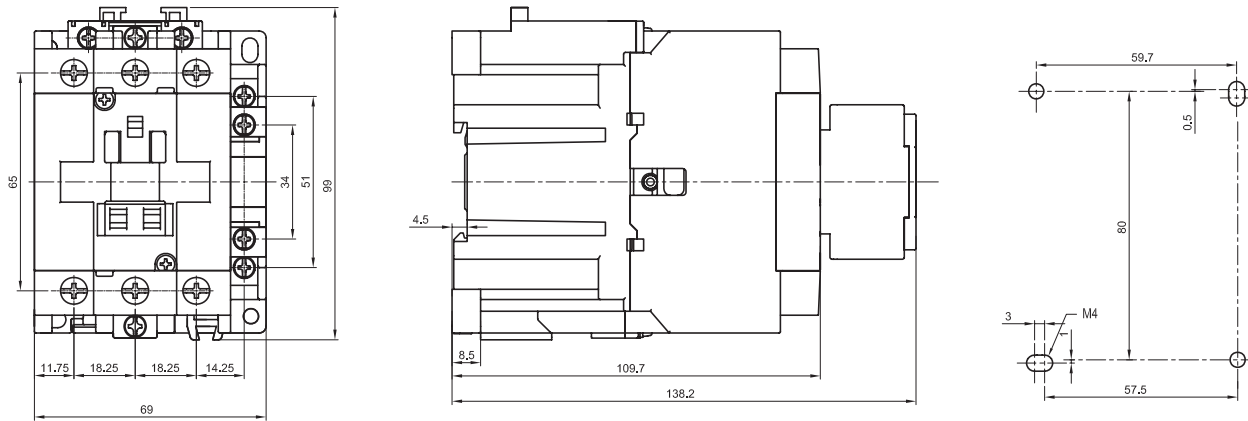

XTCD055G XTCD055G

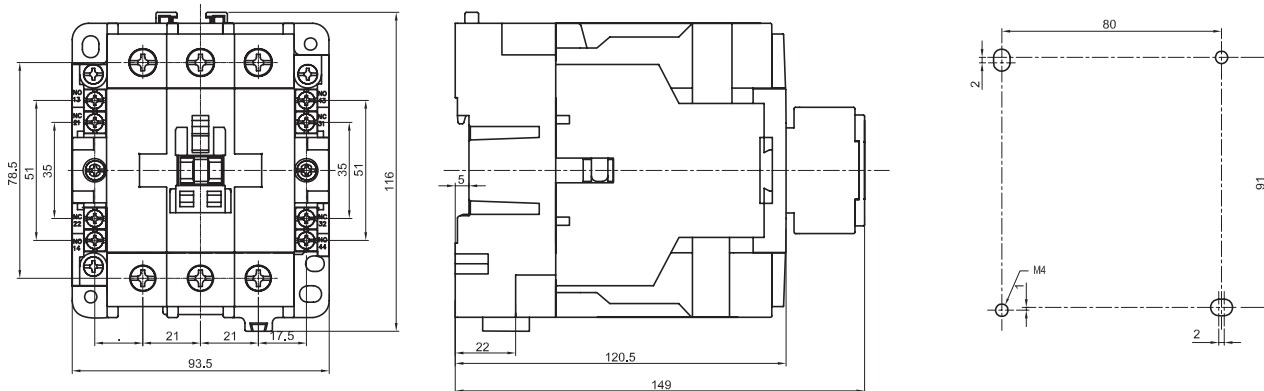

Dimensions

XTCD072G
XTCD085G

2

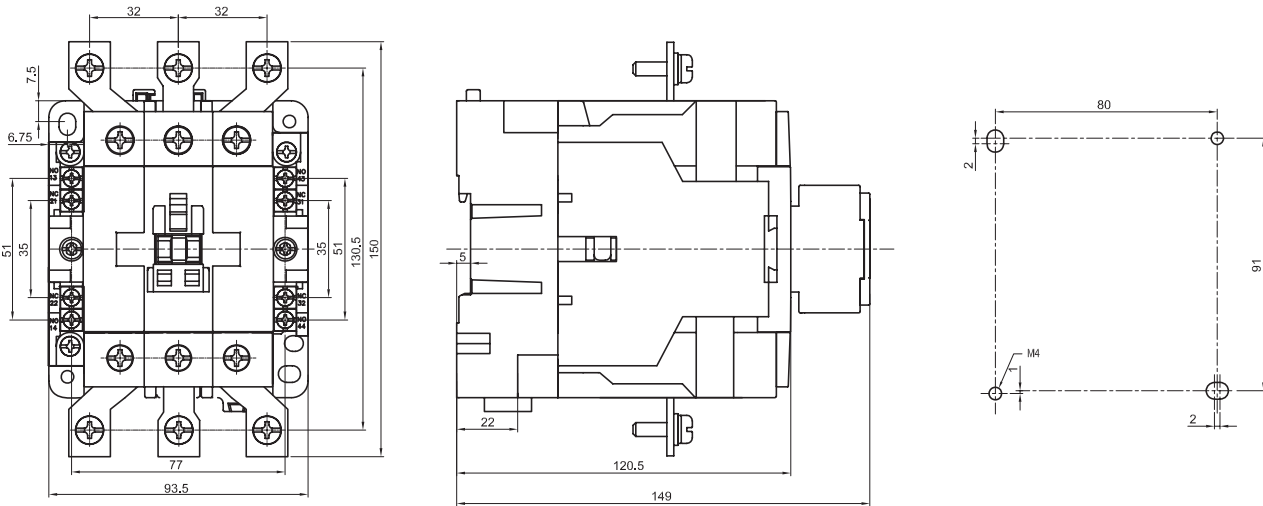

Auxiliary contact module , top mounting
XTCDXFAG(2P)

Auxiliary contact module , top mounting
XTCDXFAG(4P)

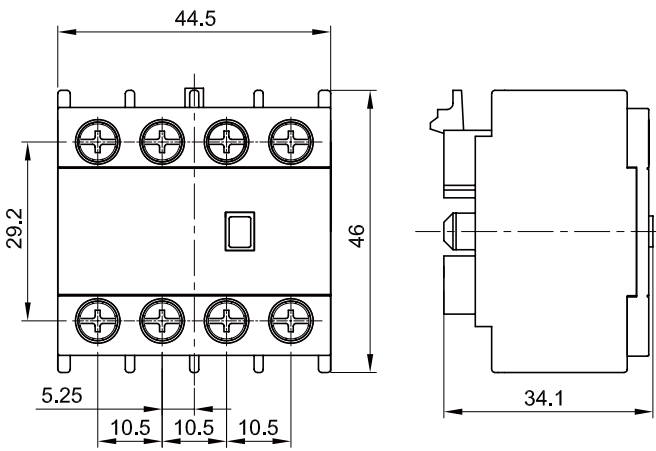
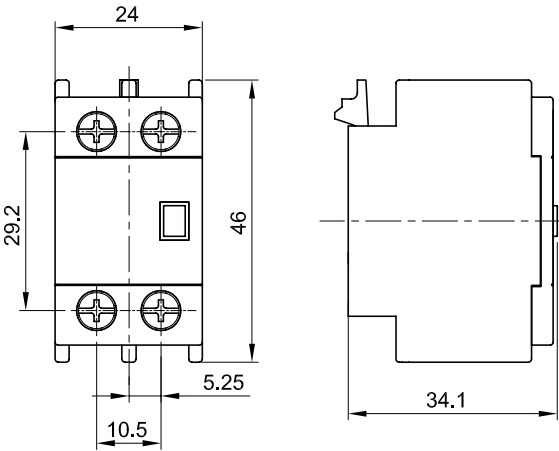

Auxiliary contact module, side mounting
XTCDXSAG

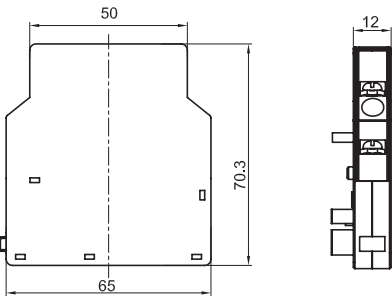

2.7 XTCD Dimension

Mechanical interlock XTCDXMLD

2

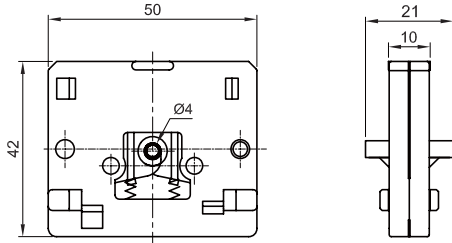

Mechanical interlock XTCDXMLG

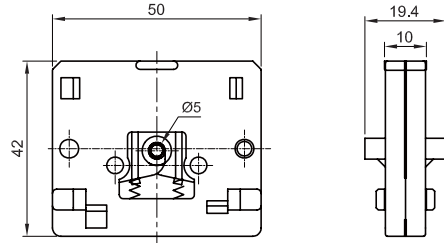

Suppressor XTCDXVSG XTCDXVRG

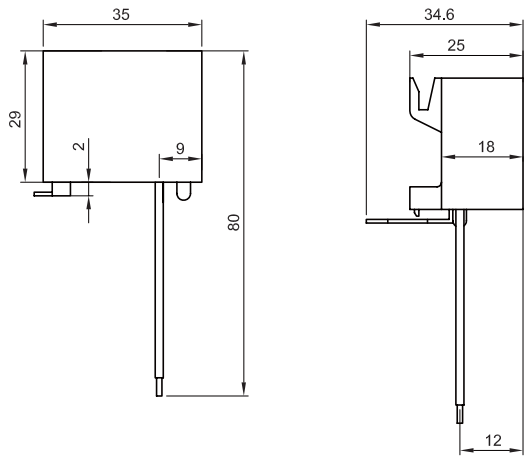

Thermal overload relays XTOD

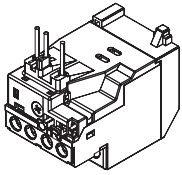

3.1 System overview	
Thermal overload relays XTOD	27
3.2 Thermal overload relays	
Thermal overload relays XTOD	28
Accessory	32
3.3 Engineering data	
Thermal overload relays XTOD.....	33
3.4 Technical data	
Thermal overload relays XTOD.....	34
3.5 Dimensions	
Thermal overload relays XTOD.....	35
Accessory	37

Thermal overload relays XTOD

Product Description

- 5 frames with current ranges up to 85A
- 1NO & 1NC auxiliary contact as standard
- Phase-loss protection available
- Selectable auto/manual reset
- Direct or panel mount

Standards and Certifications

- IEC/EN 60947
- CE
- UL/CSA (pending for availability)

System overview

Thermal overload relays

Setting range(A)
(Note the maximum current of contactor)

	XTCD007~016	XTCD022~026 XTCD032	XTCD038	XTCD040	XTCD055~085
XTOD..CC1 0.3-30					
XTOD..DC1 17-32					
XTOD..EC1 17-40					
XTOD..FC1 17-40					
XTOD..GC1 17-97					

3.2 Thermal overload relays XTOD

Thermal overload relays

Thermal overload relays

3

XTOD..CC1

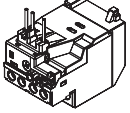

For use with		Setting range of overload releases I_r (A)	Circuit symbol	Auxiliary contact		Part no. Article no.	Standard package
				N/O = Normally open N/C = Normally closed			
XTCD007	Direct mounting	0.3~0.45		1 N/O	1 N/C	XTODP45CC1 152479	1 piece
XTCD009							
XTCD012	Direct mounting	0.45~0.67		1 N/O	1 N/C	XTODP67CC1 152480	1 piece
XTCD016	Direct mounting	0.67~1.0		1 N/O	1 N/C	XTOD001CC1 152481	1 piece
XTCD022							
XTCD026	Direct mounting	1.0~1.5		1 N/O	1 N/C	XTOD1P5CC1 152482	1 piece
XTCD032	Direct mounting	1.4~2.1		1 N/O	1 N/C	XTOD2P2CC1 152483	1 piece
	Direct mounting	1.8~2.7		1 N/O	1 N/C	XTOD2P7CC1 152484	1 piece
	Direct mounting	2.4~3.6		1 N/O	1 N/C	XTOD3P6CC1 152485	1 piece
	Direct mounting	3.5~5.0		1 N/O	1 N/C	XTOD005CC1 152486	1 piece
	Direct mounting	4.0~6.0		1 N/O	1 N/C	XTOD006CC1 152487	1 piece
	Direct mounting	5.5~8.5		1 N/O	1 N/C	XTOD8P5CC1 152488	1 piece
	Direct mounting	8.5~12.5		1 N/O	1 N/C	XTOD013CC1 152489	1 piece
	Direct mounting	12.5~18		1 N/O	1 N/C	XTOD018CC1 152490	1 piece
	Direct mounting	17~24		1 N/O	1 N/C	XTOD024CC1 152491	1 piece
	Direct mounting	22~30		1 N/O	1 N/C	XTOD030CC1 152492	1 piece

XTOD..DC1

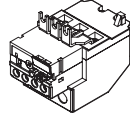

XTCD022	Direct mounting	17~25		1 N/O	1 N/C	XTOD025DC1 152493	1 piece
XTCD026							
XTCD032	Direct mounting	23~32		1 N/O	1 N/C	XTOD032DC1 152494	1 piece

XTOD..EC1

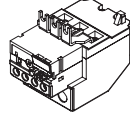

XTCD038	Direct mounting	17~25		1 N/O	1 N/C	XTOD025EC1 152495	1 piece
XTCD038	Direct mounting	23~32		1 N/O	1 N/C	XTOD032EC1 152496	1 piece
XTCD038	Direct mounting	30~40		1 N/O	1 N/C	XTOD040EC1 152497	1 piece

Overload release: tripping class 10A

Notes

Fit to the contactor directly

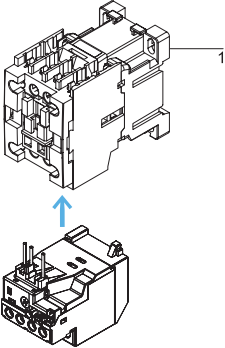

Separate Mounting

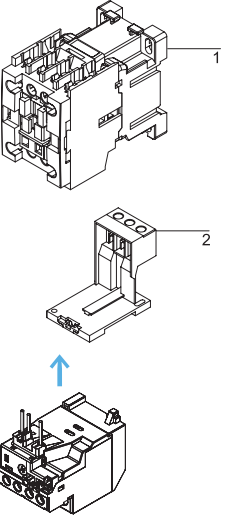

Page

- 1 Contactor → 10
- 2 Mounting Adapter → 32

Fit to the contactor directly

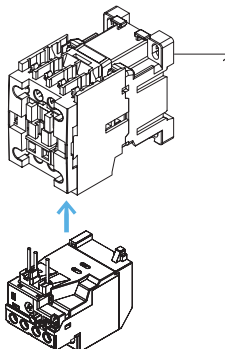

Page











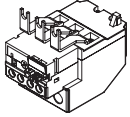



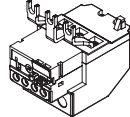



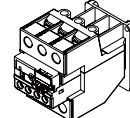

- 1 Contactor → 10

3.2 Thermal overload relays XTOD

Thermal overload relays

Thermal overload relays

3

For use with		Setting range of overload releases I_r (A)	Circuit symbol	Auxiliary contact		Part no. Article no.	Standard package
				N/O =Normally open N/C =Normally closed			
XTOD..FC1 	XTCD040	Direct mounting	17-25		1 N/O 1 N/C	XTOD025FC1 152498	1 piece
		Direct mounting	23-32		1 N/O 1 N/C	XTOD032FC1 152499	1 piece
		Direct mounting	30-40		1 N/O 1 N/C	XTOD040FC1 152500	1 piece
XTOD..GC1 	XTCD055	Direct mounting	17-25		1 N/O 1 N/C	XTOD025GC1 152501	1 piece
	XTCD065	Direct mounting	23-32		1 N/O 1 N/C	XTOD032GC1 152502	1 piece
	XTCD072						
	XTCD085	Direct mounting	30-40		1 N/O 1 N/C	XTOD040GC1 152503	1 piece
		Direct mounting	37-50		1 N/O 1 N/C	XTOD050GC1 152504	1 piece
		Direct mounting	48-65		1 N/O 1 N/C	XTOD065GC1 152505	1 piece
		Direct mounting	63-80		1 N/O 1 N/C	XTOD080GC1 152506	1 piece
	Direct mounting	77-97		1 N/O 1 N/C	XTOD097GC1 152507	1 piece	
XTOD..GC1S 	XTCD025	Direct mounting	17-25		1 N/O 1 N/C	XTOD025GC1S 152508	1 piece
	XTCD032	Direct mounting	23-32		1 N/O 1 N/C	XTOD032GC1S 152509	1 piece
	XTCD038						
	XTCD040	Direct mounting	30-40		1 N/O 1 N/C	XTOD040GC1S 152510	1 piece
	XTCD055	Direct mounting	37-50		1 N/O 1 N/C	XTOD050GC1S 152511	1 piece
	XTCD065						
	XTCD072	Direct mounting	48-65		1 N/O 1 N/C	XTOD065GC1S 152512	1 piece
	XTCD085						
		Direct mounting	63-80		1 N/O 1 N/C	XTOD080GC1S 152513	1 piece
	Direct mounting	77-97		1 N/O 1 N/C	XTOD097GC1S 152514	1 piece	

Overload release: tripping class 10A

Notes

Fit to the contactor directly

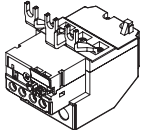
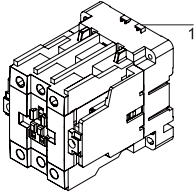

Page

1 Contactor → 10

Fit to the contactor directly

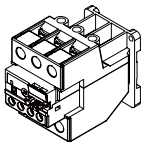
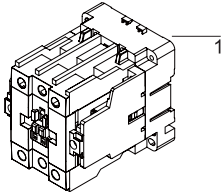

Page

1 Contactor → 10

3.2 Thermal overload relays XTOD

Accessory

Panel mounting adapter

3

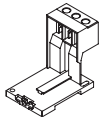

Accessory

	For use with	Part no. Article no.	Standard package
For separate mounting	XTOD..CC1	XTODXDINC 152515	1 piece

Can be snap fitted on a DIN rail to IEC/EN 60715 or can be screw fitted.

Engineering data

Items	XTOD
Phase-loss sensitivity	•
Temperature compensation	•
Auxiliary contact N/O+N/C	•
Test / release button	•
Reset button Manual/Auto	•
Separate mounting	•

Protection of single-phase:

1 pole

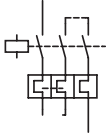

2 pole

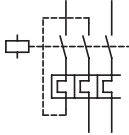

Mounting position:

XTOD

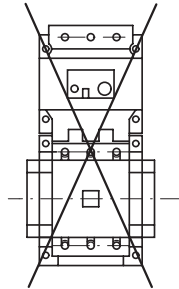

3.4 Thermal overload relays XTOD

Technical data

General

		XTOD..CC1	XTOD..DC1	XTOD..EC1	XTOD..FC1	XTOD..GC1
Standards		IEC/EN 60947, GB 14048				
3 Climatic Proofing		Damp heat, constant, to IEC60068-2-78				
		Damp heat, cyclic, to IEC60068-2-30				
Ambient temperature						
Open	°C	-25-55	-25-55	-25-55	-25-55	-25-55
Enclosed	°C	-25-40	-25-40	-25-40	-25-40	-25-40
Temperature compensation	°C	-5-40	-5-40	-5-40	-5-40	-5-40
Mounting position		→ 33	→ 33	→ 33	→ 33	→ 33
Weight	kg	0.15	0.15	0.25	1.64	1.64
Protection type		IP20	IP20	IP00	IP00	IP00

Main contacts

Rated impulse withstand voltage	U_{imp}	VAC	6000	6000	6000	6000	6000
Overvoltage category/pollution degree			III/3	III/3	III/3	III/3	III/3

Rated insulation voltage

AC	U_i	VAC	690	690	690	690	690
Rated operational voltage	U_e	VAC	600	600	600	600	600
Overload release setting range		A	0.3-30	17-32	17-40	17-40	17-97

Terminal capacity

Solid	mm ²	1 x (1-6)	1 x (2.5-16)	1 x (2.5-16)	1 x (2.5-16)	1 x (2.5-16)
		2 x (1-6)	2 x (2.5-16)	2 x (2.5-16)	2 x (2.5-16)	2 x (2.5-16)
Flexible with ferrule	mm ²	1 x (1-6)	1 x (1-6)	1 x (1-6)	1 x (1-6)	1 x (1-6)
		2 x (1-6)	2 x (1-6)	2 x (1-6)	2 x (1-6)	2 x (1-6)
Solid/stranded	AWG					
Terminal screw		M4	M5	M5	M5	M5
Tightening torque	Nm	1.2	2.5	2.5	2.5	2.5

Auxiliary and control circuits

Rated impulse withstand voltage	U_{imp}	V	6000	6000	6000	6000	6000
Overvoltage category/pollution degree			III/3	III/3	III/3	III/3	III/3

Terminal capacity

Solid	mm ²	1 x (1-6)	1 x (1-6)	1 x (1-6)	1 x (1-6)	1 x (1-6)
		2 x (1-6)	2 x (1-6)	2 x (1-6)	2 x (1-6)	2 x (1-6)
Flexible with ferrule	mm ²	1 x (1-6)	1 x (1-6)	1 x (1-6)	1 x (1-6)	1 x (1-6)
		2 x (1-6)	2 x (1-6)	2 x (1-6)	2 x (1-6)	2 x (1-6)
Solid/stranded	AWG					
Terminal screw		M3.5	M3.5	M3.5	M3.5	M3.5
Tightening torque	Nm	0.8	0.8	0.8	0.8	0.8

Rated insulation voltage	U_i	VAC	690	690	690	690	690
Rated operational voltage	U_e	VAC	600	600	600	600	600
Conventional thermal current	I_{th}	A	10	10	10	10	10
Rated operational current							

AC-15							
120V	I_e	A	6	6	6	6	6
220/240V	I_e	A	3	3	3	3	3
380V	I_e	A	1.9	1.9	1.9	1.9	1.9
480V	I_e	A	1.5	1.5	1.5	1.5	1.5
500V	I_e	A	1.4	1.4	1.4	1.4	1.4
600V	I_e	A	1.2	1.2	1.2	1.2	1.2

DC-13							
125V	I_e	A	0.55	0.55	0.55	0.55	0.55
250V	I_e	A	0.27	0.27	0.27	0.27	0.27

Dimensions

**Thermal overload relay
XTOD..CC1**

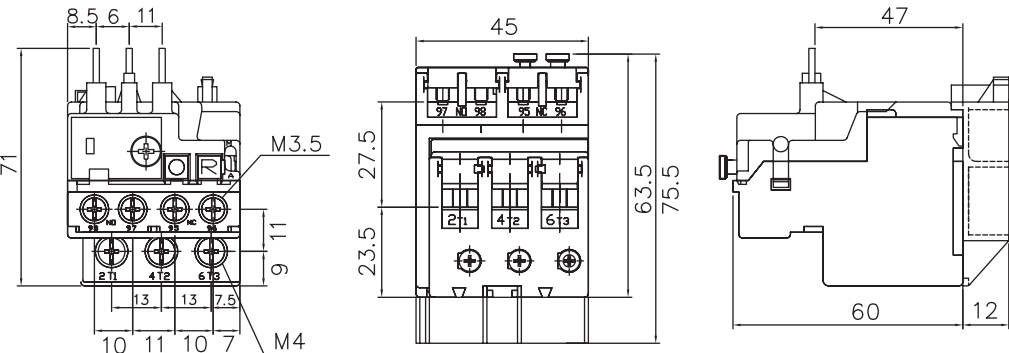

XTOD..DC1

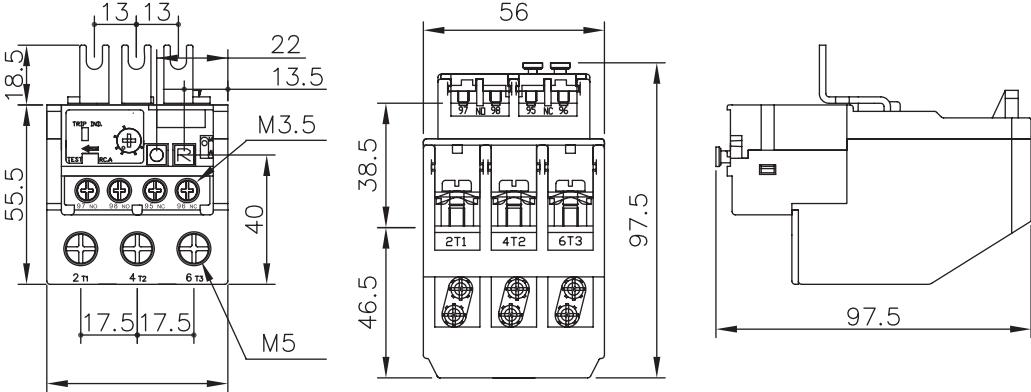

XTOD..EC1

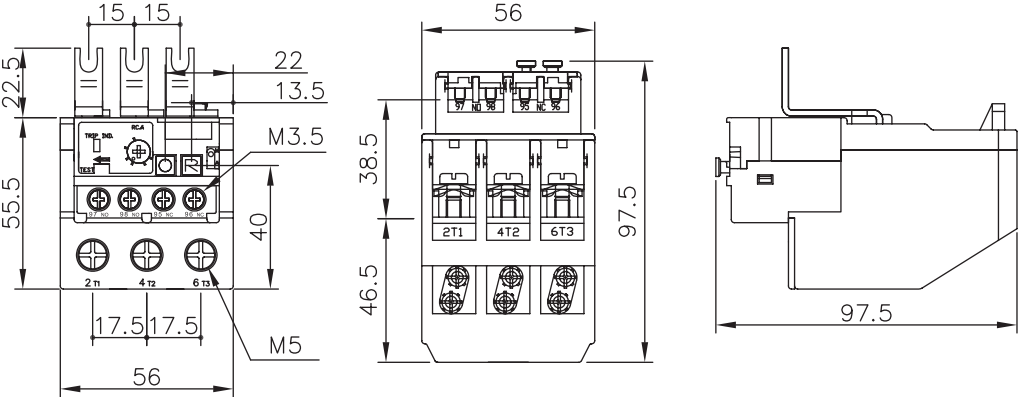

3.5 Thermal overload relays XTOD

Dimensions

Dimensions

Thermal overload relay XTOD..FC1

3

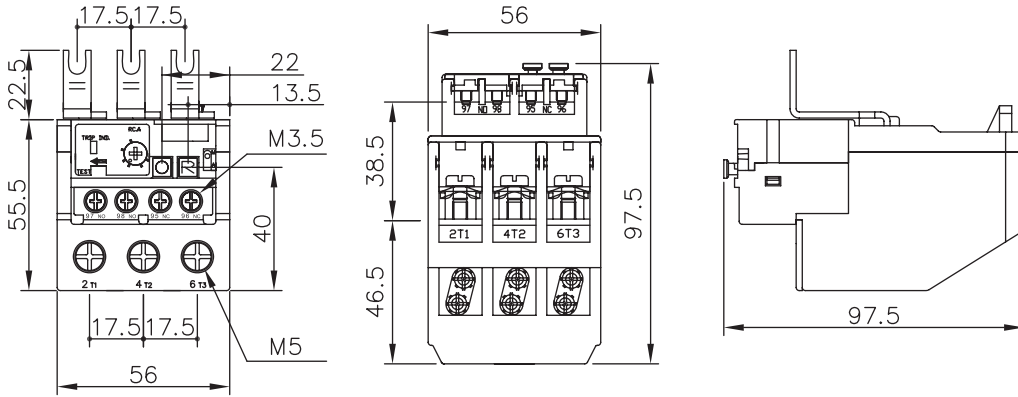

XTOD..GC1

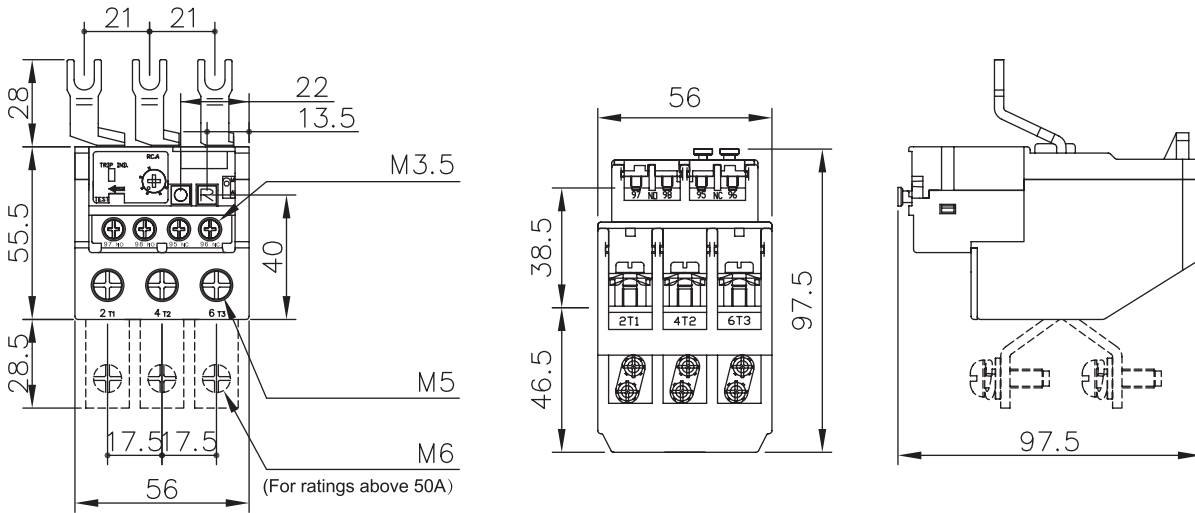

XTOD..GC1S

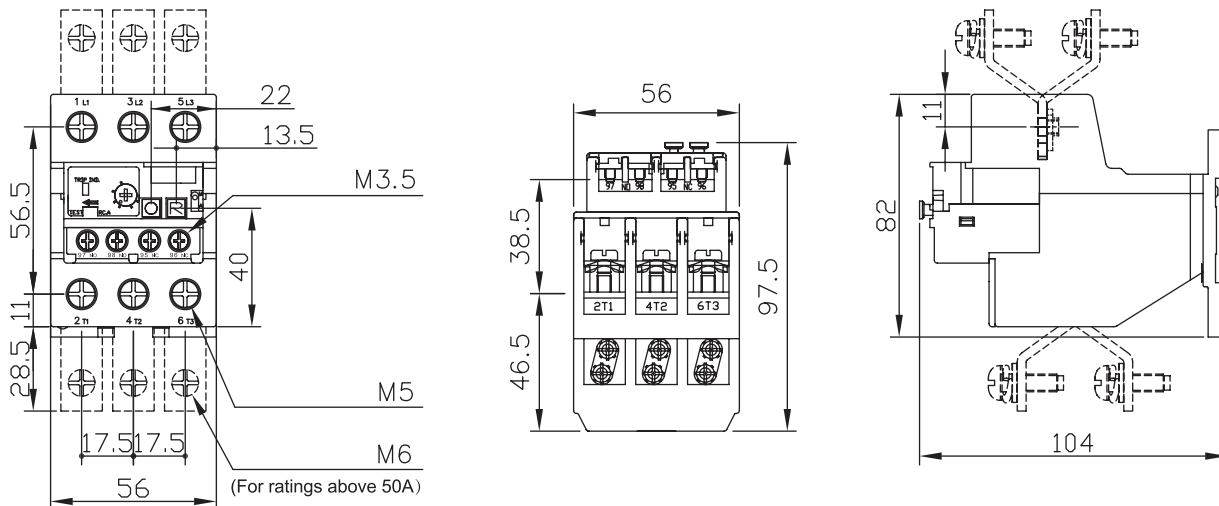

Dimensions

Thermal overload relay + mounting adapter
XTOD..CC1+XTODXDINC

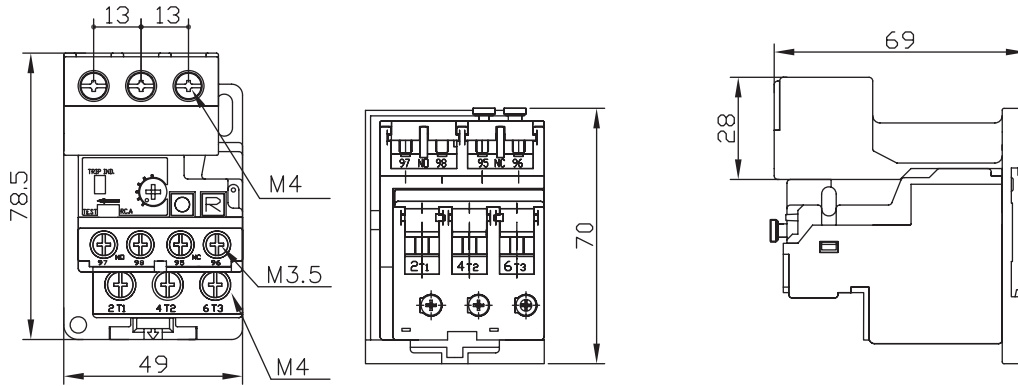

Eaton's Electrical Sector is a global leader in power distribution, power quality, control and automation, and monitoring products. When combined with Eaton's full-scale engineering services, these products provide customer-driven PowerChain Management solutions to serve the power system needs of the data center, industrial, institutional, public sector, utility, commercial, residential, IT, mission critical, alternative energy and OEM markets worldwide.

PowerChain Management solutions help enterprises achieve sustainable and competitive advantages through proactive management of the power system as a strategic, integrated asset throughout its life cycle, resulting in enhanced safety, greater reliability and energy efficiency. For more information, visit www.eaton.com/electrical.